

# **QUAIFE**®

Automotive engineering - from design to production

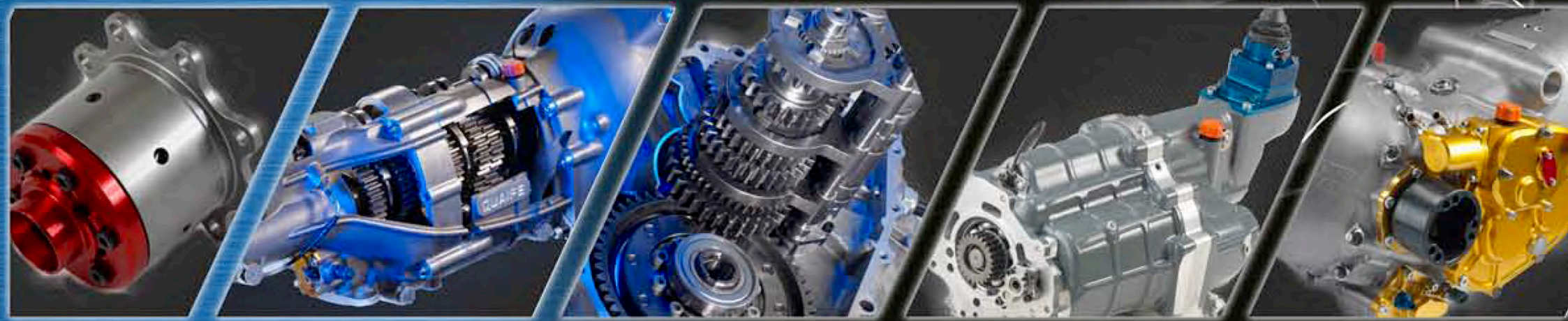

Product Catalogue **2015**



**RT Quaife Engineering Limited**

Vestry Road, Otford, Sevenoaks, Kent TN14 5EL United Kingdom

Tel: +44 (0)1732 741144

Fax: +44 (0)1732 741555

Email: [info@quaife.co.uk](mailto:info@quaife.co.uk)Web: [www.quaife.co.uk](http://www.quaife.co.uk)

Telephone lines are open from Monday-Thursday 8.00am-5.30pm,  
Friday 8.00am-3.30pm.

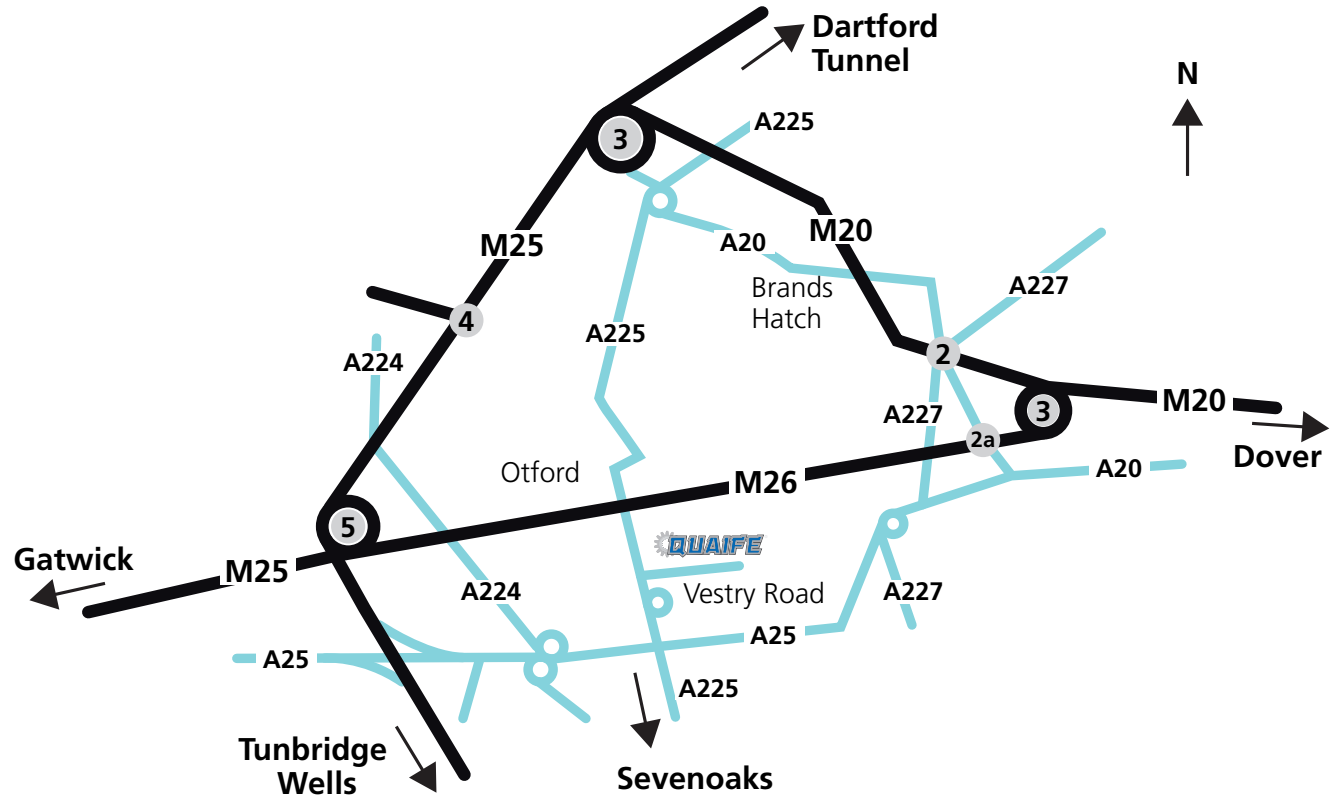

# automotive engineering – from design to production

Information and prices within this brochure may change without prior notification.

Products may vary from the catalogue photographs.

Lifetime warranty on Quaife ATB differentials – subject to terms and conditions.

**All prices shown exclude VAT.**

**Freight can be arranged door-to-door – worldwide.**

**Telephone calls are recorded for training purposes.**





<b>4</b>	New Gearboxes	<b>35</b>	Honda Sequential	<b>62</b>	Rocket 4-Speed Gearkits	<b>82</b>	Subaru Gearkits	<b>105</b>	Tran-X Sierra 5-Speed Gearkits
<b>5</b>	Gearbox Packages	<b>36</b>	KIA Sequential	<b>63</b>	Sierra 5-Speed Gearkits	<b>83</b>	Saab Gearkit	<b>106</b>	Servicing
<b>6-15</b>	Quaife ATB Differentials	<b>37</b>	Toyota Sequential (EC60)	<b>64</b>	Bullet 4-Speed Gearkits	<b>83</b>	Toyota Gearkit	<b>107</b>	Lubricants
<b>16</b>	In-line 60G Sequential	<b>38</b>	Toyota Sequential (C64)	<b>65</b>	Escort Sport Gearkit	<b>84-86</b>	VAG Gearkits		
<b>17</b>	In-line 69G Sequential	<b>39</b>	Rover (PG1) Sequential	<b>65</b>	Borg Warner T5 Gearkit	<b>87-88</b>	Vauxhall / Opel Gearkits		
<b>18-19</b>	In-line Accessories	<b>40</b>	Mitsubishi Evo Sequential	<b>66</b>	Ford Gearbox Identification	<b>89</b>	Opel Manta Gearkit		
<b>20</b>	Ford RS 200 Sequential	<b>41</b>	Ford MT75 4WD	<b>67-68</b>	Ford IB5 Gearkits	<b>89</b>	Volvo 240 Gearkit		
<b>21</b>	Chevrolet Corvette Sequential	<b>42-43</b>	Rocket 4-Speed Gearboxes	<b>69</b>	Ford MTX75 Gearkits	<b>90</b>	English / Atlas Axle Kit		
<b>22</b>	Transaxle 61G Sequential	<b>44-45</b>	Sierra 5-Speed Gearboxes	<b>70</b>	Honda Civic Gearkits	<b>91</b>	English / Atlas 2-piece halfshafts		
<b>23</b>	Transaxle 72G Sequential	<b>46-49</b>	Rocket / Sierra Accessories	<b>71</b>	Morgan / Jaguar Gearkit	<b>92</b>	Complete Axles		
<b>24</b>	Transaxle 62G H-pattern	<b>50-53</b>	Motorcycle Engined Vehicles	<b>71</b>	Land Rover R380 Gearkit	<b>93</b>	Complete Diff Assemblies		
<b>25</b>	Transaxle 85G Sequential	<b>54-55</b>	Off Road Winches	<b>72-73</b>	Rover PG1 Gearkits	<b>94-95</b>	Steering Racks		
<b>26</b>	In-line H-pattern	<b>56</b>	Lotus Elan Components	<b>74</b>	Lotus ZF 4-Speed	<b>96</b>	Tran-X		
<b>27</b>	In-line 89G Sequential	<b>57</b>	Norton Motorcycles	<b>75</b>	Mazda MX5 / RX7	<b>97</b>	Tran-X Crownwheel & Pinion Kits		
<b>28</b>	In-line 4x4 87G Sequential	<b>58</b>	Triumph Motorcycles	<b>76</b>	MG Midget Gearkit	<b>98-102</b>	Tran-X Plate-Type LSD		
<b>29</b>	In-line 4x4 86G Sequential	<b>59</b>	Velocette Motorcycles	<b>76</b>	BMW Mini Gearkit	<b>102</b>	Tran-X Halfshafts & Flanges		
<b>30</b>	In-line 4x4 91G Sequential	<b>59</b>	Vincent Motorcycles	<b>77</b>	Mitsubishi Evo Gearkits	<b>103</b>	Tran-X Rocket Synchromesh Gearkits		
<b>31</b>	Transaxle 81G Sequential	<b>60</b>	Alfa-Romeo	<b>78</b>	Nissan Gearkits	<b>104</b>	Tran-X Sierra 5-Speed Helical Gearkits		
<b>32</b>	In-line with drop gears	<b>60</b>	Austin Healey	<b>79-80</b>	Peugeot / Citroën Gearkits				
<b>34</b>	Ford IB5 Sequential	<b>61</b>	Classic Mini	<b>81</b>	Renault UN1 Gearkits				

The Quaife modular range are advanced, compact six speed sequential gearboxes that set a new industry benchmark for size, performance and standard levels of equipment. Specified for use in lightweight performance applications up to 375 bhp, the range features Quaife's proven modular transmission technology enabling a greater choice of user definable gear ratios, some using Quaife's Quick-Change drop gear system. This makes the range ideal for highly tuned, free revving engines and the rigours of competitive motorsport.

Designed from the outset to be a fully paddleshift compatible, the Quaife modular range incorporates high strength aircraft specification aluminium casings, a robust 85mm shaft layout and durable EN39 steel gears in a package significantly shorter and lighter than Quaife's previous generation of gearboxes

#### Gear Ratios (Spur)

1st	2nd	3rd	4th	5th	6th
2.833	2.071	1.813	1.611	1.444	1.316
		1.730	1.500	1.350	1.200
				1.300	1.136
					1.105
2.438	1.889	1.500	1.238	1.043	0.897
			1.286	1.115	0.958

#### Drop Gear Ratios

3.056	3.310	3.375	3.750	4.067
-------	-------	-------	-------	-------

#### £POA

#### Enquire now:

Tel: +44 (0)1732 741144

Fax: +44 (0)1732 741555

Email: [info@quaife.co.uk](mailto:info@quaife.co.uk)

Web: [www.quaife.co.uk](http://www.quaife.co.uk)

#### QBM2M Front Wheel Drive 6-speed Sequential Gearbox

QBM2M features an innovative range of alloy adaptor rings to suit a wide variety of popular powerplants and incorporates a fitted carbon fibre bellhousing cover for ultimate weight saving. The output shafts can be fitted with 110 Lobro or 3-ear Tripode joints for commonly found drive shafts. A wide variety of clutch spline options and a choice of either ATB or plate style differentials are available, accessible via a detachable cover to enable rapid servicing.



#### QBM3M Transaxle 6-speed Sequential Gearbox

QBM3M covers a wide range of possible installations with its removable bellhousings. Different lengths and splines of quill shaft are available on request to suit most popular powerplants. Customers can specify a choice of either a Quaife ATB differential or a clutch-plate style LSD accessed via a single cover for rapid servicing. QBM3M is designed to keep the differential drive flange width the same as previous Quaife products and can therefore be a direct upgrade for older transaxle gearboxes.



#### QBM4M Transverse 6-speed Sequential Gearbox

QBM4M is designed to be ultra-compact with a transverse gear cluster keeping total length to an absolute minimum. The removable bellhousings and choice of quill shafts ensures that QBM4M fits the widest possible range of popular powerplants, while Quaife can design bespoke installations to suit individual requirements. Just as the others in the range, customers can specify a choice of either a Quaife ATB differential or a clutch-plate style LSD accessed via a single cover for rapid servicing.



PLEASE NOTE: QBM2M, QBM3M and QBM4M are supplied as standard with a lightweight carbon fibre gear lever and cable as well as a digital gear position indicator and integral oil pump.



Throughout 50 years of the design, manufacture and supply of transmissions to the motorsport industry Quaife have been asked to adapt products to fit a vast range of engines in everything from road modified cars to custom built space-frame racing machines. To extend this further Quaife have designed a range of packages to ensure the easiest possible installation into the most popular motorsport applications. Along with our inline 6-speed sequential transmissions, Quaife can supply off-the shelf bellhousings with the correct input shaft length and clutch spline arrangement to retain the stock clutch and engine mounting positions whilst retaining the original gear lever position in the vehicle. Some of the popular packages are shown here and can be purchased as complete packages or as adapter kits for existing Quaife gearboxes from our sales team or straight from our webshop (see contact details below).

Where a specific fitment package is not yet available, Quaife's in-house design team can create bolt on or weld on adapter plates for most other applications, even if the original bellhousing is part of the main gearbox casing. Quaife regularly manufacture profiled adapter plates from high quality aluminium plate and spline-cut blank off-the-shelf input shafts for bespoke vehicle fitments. Please ask for more information and bespoke quotations.

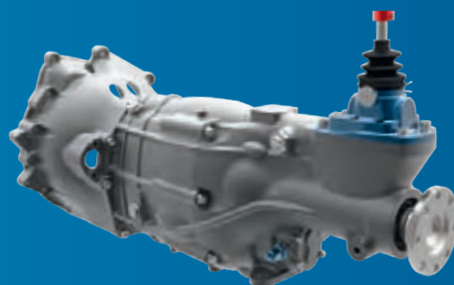

QBE60G / QBE69G - BMW N47 / N52 / S50 / S54



QBE60G / QBE69G - Chevrolet LS3 / LS5 / LS7



QBE60G / QBE69G - Honda S2000



QBE60G / QBE69G - Mazda MX5 (Mk1 / Mk2)

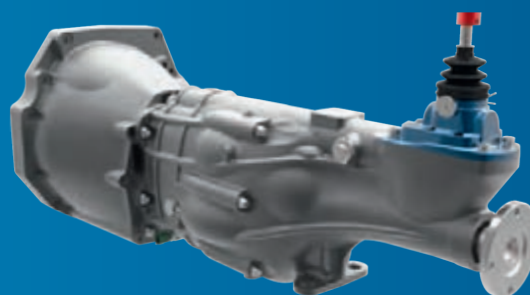

QBE60G / QBE69G - Nissan SR20

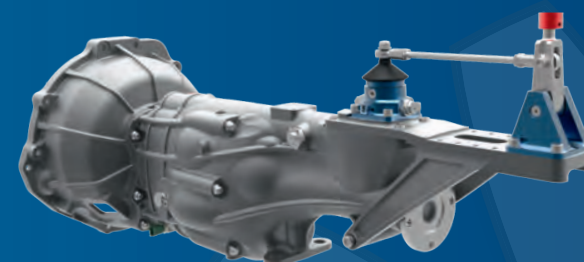

QBE60G / QBE69G - Nissan 350Z (-2006)



QBE60G / QBE69G - Nissan 350Z (2007+)



QBE60G / QBE69G - Toyota GT86 (BRZ / FR-S)

## £POA

### Enquire now:

Tel: +44 (0)1732 741144

Fax: +44 (0)1732 741555

Email: [info@quaife.co.uk](mailto:info@quaife.co.uk)

Web: [www.quaife.co.uk](http://www.quaife.co.uk)

# More traction, more speed, more control with Quaife ATB helical gear limited slip differential



The Quaife Automatic Torque Biasing (ATB) helical gear limited slip differential has been in continuous production since the 1980's and is renowned for its performance, quality and reliability. Whether you are a racing driver, a trackday addict or simply live in a snowy region of the world, the Quaife ATB differential is the perfect traction solution.

Available for a vast range of popular front, rear and four wheel drive cars, the Quaife ATB differential is used in a huge variety of motorsport disciplines including rallying, circuit racing, sprinting, rallycross, drifting and oval racing. The Quaife ATB is also frequently chosen by owners of highly tuned road cars looking to improve their vehicle's traction, particularly in front wheel drive applications.

Selected by GM, Chrysler and Ford as an OEM fitment (most recently by Ford in its amazing 300bhp Focus RS and RS500 models) the Quaife ATB limited slip differential offers a number of advantages over a conventional, plate-style differential.

Quaife ATB differential units are manufactured in the United Kingdom and inspected to ISO9001-2008 standards. The Quaife ATB differential uses a well-proven, durable internal system of helical gears – there are no plates, springs or other components to replace...ever.

The Quaife ATB differential has been designed to use the standard transmission oils and is covered by a limited lifetime warranty for both road and competition use. This makes the Quaife ATB differential a true 'fit and forget' upgrade that offers compromise-free performance and reliability. Key features of the Quaife ATB helical gear limited slip differential include:

- Safe, progressive and seamless in action, the Quaife ATB differential never 'locks'
- Controlled power is transmitted to all driven wheels, to maximise traction and minimise wheelspin, particularly in slippery conditions
- Fitment eliminates unwanted torque steer, understeer or oversteer
- Designed to work in harmony with road car OEM electronic stability programs
- Improves braking performance by reducing lock ups and minimises ABS intrusion
- Reduces tyre wear, especially on front wheel drive cars
- Gear operated with no components to replace – ever
- Direct replacement for factory standard 'open' differential unit
- Retains normal axle lubrication systems and maintenance schedule
- Over 100,000 units sold worldwide since the 1980's
- Backed by the confidence of a Quaife lifetime warranty

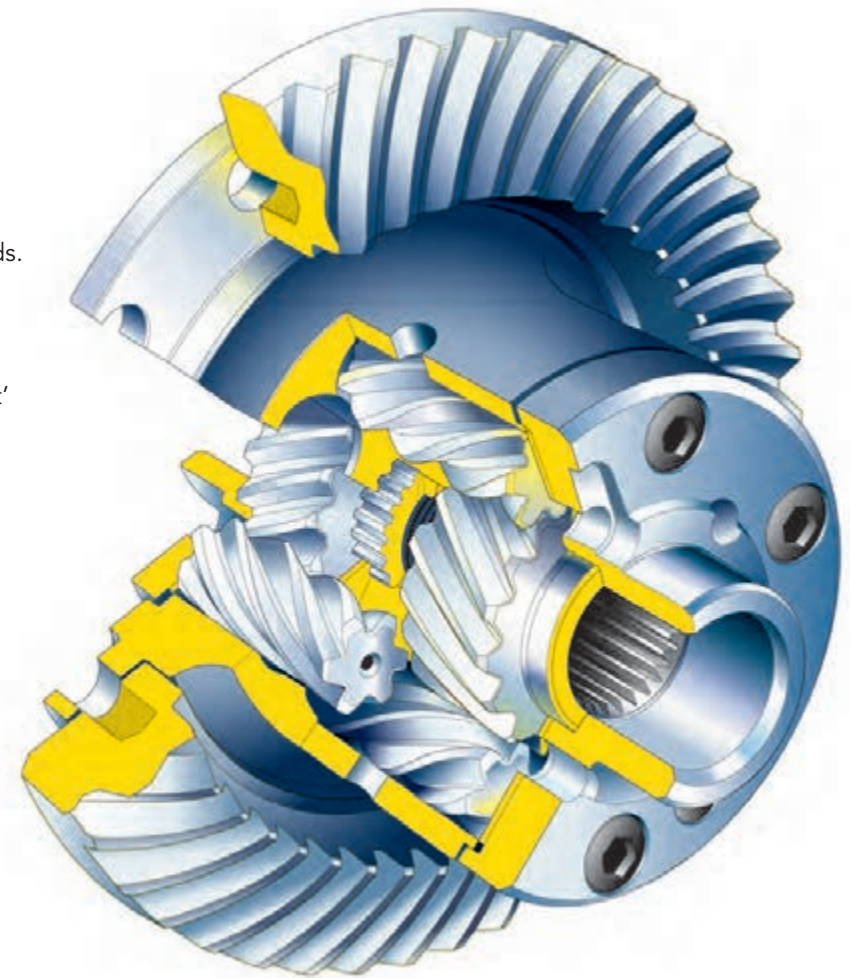
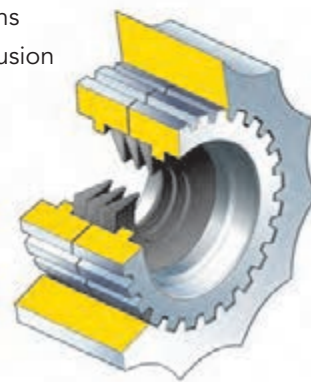



## Quaife ATB differentials

The Quaife Automatic Torque Biasing (ATB) helical gear limited slip differential is designed to prevent the complete loss of drive that occurs with a conventional 'open' differential when one wheel spins. Whilst requiring some torque in the slipping wheel to function, the Quaife ATB is progressive in action but never locks – controlled power is transmitted to all the driving wheels. Ideally suited to high powered front wheel drive cars, Quaife ATB differentials also benefit rear and four wheel drive vehicles where optimum traction is required.

A direct replacement for a factory 'open' differential, no special oils are required and the standard transmission lubrication can be retained. Lubrication services should be observed at factory intervals or more frequently for Quaife ATB units subjected to motorsport use.

The range of Quaife ATB differential applications is being continuously expanded – new fitments for 2015 are **highlighted in red**.



Alfa Romeo Alfasud 8 bolt & 10 bolt	QDH4E	<b>£680.00</b>	Audi A3 1.8, 1.8T, Tdi (02J)	QDF10R	<b>£615.00</b>
Alfa Romeo 156 2.5 V6, 156 GTA, 147 GTA, GT 3.2, 166	QDH6E	<b>£680.00</b>	Audi A3 2.0-litre TFSI Sport / A3 Sportback 2.0-litre TFSI (02Q)	QDF16R	<b>£615.00</b>
Alfa Romeo 145, 155, 916 Spider, GTV, GT, 147, 156	QDH2K	<b>£615.00</b>	Audi (front) TT, A3 2WD (02M)	QDF13R	<b>£615.00</b>
Alfa Romeo MiTo, 155 TB, 159 JTD	QDF25B	<b>£615.00</b>	Audi (front) TT Quattro (2008+), S3 Quattro (2006+) 4WD (02Q)	QDF23R	<b>£680.00</b>
Alfa Romeo 159 / Brera 2.4 JTD	QDF21B	<b>£615.00</b>	Audi (front) TT Quattro, S3 Quattro 4WD (02M)	QDF14R	<b>£680.00</b>
Alfa Romeo MiTo QV (2010+)	QDH7E	<b>£680.00</b>	Audi (front), S4, S6, A6 4.2l (01E)	QDF8Q	<b>£815.00</b>
Audi (front), Coupe GT, 4000 Quattro, Quattro (016/093)	QDF4Q	<b>£815.00</b>	Audi (front) S3 Quattro DSG 4WD c/w bolt kit (25T brake ring)	QDF25R	<b>£815.00</b>
Audi (front), A4 2WD (pre-1999, 012/DUK)	QDF6Q	<b>£815.00</b>	Austin Healey 3000	QDF13K/10	<b>£POA</b>
Audi (rear), A4 Quattro	QDF4Q	<b>£815.00</b>	Austin Healey Sprite	QDF5K	<b>£575.00</b>

# Quaife ATB differentials

Austin Rover Mini Cooper S (Hardy Spicer)	QDF14K	£POA	Citroën SM / DS	QDF13H	£POA
Austin Rover Mini (Pot Joint)	QDF36K	£POA	Citroën GSA	QDF17H	£POA
Birkin	QDH1L	£680.00	Daewoo Matiz 1995	QDF33B	£POA
BMW 2002	QDF4N	£POA	Dodge Charger SRT-8	QDF9V	£815.00
BMW Z3 4 cyl / 318ti (E36)	QDF6N	£POA	Dodge Neon, Avenger, Sircus (T350 trans)	QDF3I	£680.00
BMW 325i (E30 / E36) / 525-535i (E28 / E34) / 633-635csi / 735i	QDF2N	£POA	Dodge Neon SRT-4 (T850 trans)	QDH1U	£615.00
BMW M3 (E30) / (E36 – 3.0l only)	QDF2N	£POA	Dodge Viper V10 (Dana 44 axle) Viper 1 upto 2002	QDF9S	£815.00
BMW 328i (E36)	QDF3N	£POA	Dodge Viper SRT-10 Viper II 2003 onwards	QDH4U	£815.00
BMW M3 (E36 3.2l / E46), M5 (E34)	QDF5N	£POA	Dodge Shelby FWD	QDF16B	£615.00
BMW 540i (E39)	QDF8N	£POA	Ferrari 340 Mexico (1952)	QDH2D	£POA
BMW 850, Z8, 330d (E46), 335i (E92)	QDF10N	£POA	Ferrari 330	QDH3D	£POA
BMW 130i / 330i (E36)	QDF13N	£POA	Ferrari 275 GTB	QDH5D	£POA
BMW 330 (E46)	QDF14N	£POA	Ferrari 212	QDH6D	£POA
BMW 530d (E60)	QDF15N	£POA	Fiat 500 (Not Abarth)	QDH3K	£615.00
BMW 320i, 120i	QDF16N	£POA	Fiat 500 Abarth / Abarth EVO	QDH2K	£615.00
Caterham (De'Dion axle)	QDF15Z	£575.00	Fiat Uno / Punto / Grande Punto / Idea / Tipo / Tempra / Bravo / Marea Stilo / Multipla / Palio / Siena / Coupe / Barchetta / Strada (New) / Doblo	QDH2K	£615.00
Caterham (English axle)	QDF5Z	£460.00			
Caterham (Ital/Marina axle)	QDF8K	£575.00			
Chevrolet Corvette C5 97-04 (inc Z06)	QDF22B	£815.00			
Chevrolet Corvette C6 Z06	QDF24B	£815.00			
Chrysler Sebring, Cirrus (T350 trans)	QDF3I	£680.00			
Chrysler 300C 5.7L Hemi / SRT8	QDF9V	£815.00			
Citroën AX, Saxo VTR & VTS, C2 (MA gearbox)	QDF9H	£575.00			
Citroën ZX (BE3 gearbox)	QDF3H	£575.00			
Citroën 2CV	QDF11H	£POA			





Fiat Grande Punto TD	QDF25B	<b>£615.00</b>
Ford Atlas (16t or 18t spline)	QDF6Z	<b>£680.00</b>
Ford English (22t or 16t spline)	QDF5Z	<b>£475.00</b>
Ford Escort / Sierra 6½" 4x4 heavy duty front differential case	F18Z1-02	<b>£795.00</b>
Ford Escort / Sierra 6½" 4x4 front	QDF16Z	<b>£615.00</b>
Ford Escort Cosworth rear, XR4x4 (including flanges)	QDF15ZFL	<b>£815.00</b>
Ford Explorer (4x4) front	QDF37Z	<b>£815.00</b>
Ford Focus ST170 (SVT/Getrag 285)	QDF38Z	<b>£575.00</b>
Ford Focus Mk2 ST – M66	QDF13J	<b>£615.00</b>
Ford Escort / Fiesta / Focus / Ka / Orion / Puma (BC / IB5 trans)	QDF7Z	<b>£575.00</b>
Ford Ka Mk2 (2008+)	QDH3K	<b>£615.00</b>
Ford MTX75 / Contour (USA) / Focus / Mondeo / RS2000	QDF20Z	<b>£575.00</b>
Ford Granada Mk1 & Mk2	QDF48Z	<b>£680.00</b>
Ford Fiesta ST180 / Focus (1.6l Ecoboost) IB6	QDF57Z	<b>£POA</b>
Ford Probe GT V6 (G-type trans)	QDF6F	<b>£615.00</b>
Ford Sierra 7"	QDF15Z	<b>£575.00</b>
Ford Sierra / Granada 7½" rear (including flanges)	QDF14ZC	<b>£815.00</b>
Cosworth 108mm Lobro	QDF14ZS	<b>£815.00</b>
Scorpio 100mm Lobro	QDF14ZF	<b>£815.00</b>
Ford Sierra Cosworth 7½" front (including shafts)	QDF41Z	<b>£POA</b>
Ford Mondeo ST220 + Focus Mk3 ST250 – MMT6	QDF41Z	<b>£POA</b>
Ford 9"	QDH1R	<b>£575.00</b>
Hewland FT (Formula Atlantic) (with alloy end cover)	QDF7S	<b>£680.00</b>
Hewland FT200	QDF8S	<b>£680.00</b>
Hewland MK9 (Formula 3) (with alloy end cover)	QDF2S	<b>£680.00</b>



Hewland JFR/FTR (FTR-212-FD & Powerflow replacement)	QDF14S	<b>£815.00</b>
Hillman Imp (including flanges)	QDF14HFL	<b>£POA</b>
Hillman Avenger	QDF1H	<b>£615.00</b>
Honda Integra GS / LS '90-'00, Integra GS-R 92-93, Y21	QDF1U	<b>£575.00</b>
Honda Civic EK4 / CRX (Del Sol) Vtec, Civic Si '99-'00 Vtec	QDF1U	<b>£575.00</b>
Honda Civic EK3 / CRX (Del Sol) Non Vtec, 40mm bearings	QDF2U	<b>£615.00</b>
Honda Civic City, 35mm bearings	QDF3U	<b>£615.00</b>
Honda Civic EG / CRX ('90-'91) Si, plus non Si / Ex ('88-'99) 35mm bearings	QDF4U	<b>£575.00</b>
Honda Accord '90-'97, Prelude '92-'96, Prelude '97-'00 (except SH)	QDF5U	<b>£575.00</b>
Honda Acura Integra GS-R '94-'00 / Civic Type R EK9 40mm bearings	QDF6U	<b>£575.00</b>
Honda Civic SRX Si / EX models '88-'89, except '90-'91 Si 40mm bearings	QDF7U	<b>£615.00</b>
Honda Civic EP3, FD2, FN2 (K20/K24) / Integra DC5 / Acura RSX, TSX	QDF9U	<b>£POA</b>
Honda EP3, FD2, FN2, DC5 (K20/K24) – DSS 28T STD Bearings	QDF17U	<b>£680.00</b>
Honda EP3, FD2, FN2, DC5 (K20/K24) – DSS 28T HD Bearings	QDF18U	<b>£895.00</b>
Honda S2000 / Synthesis	QDF14U	<b>£615.00</b>
Honda Fit / Jazz Mk1 (2001-2008)	QDF15U	<b>£615.00</b>

# Quaife ATB differentials

Honda Fit / Jazz Mk2 (2008+)	QDF16U	£615.00	Land Rover Freelander	QDF31K	£615.00
Hyundai Coupe / Tiburon – 6-speed	QDH14B	£680.00	Land Rover / Range Rover centre (suffix G requires early hub)		
Hyundai Accent	QDH4B	£615.00	LT230R	QDF30KR	£815.00
Hyundai Genesis	QDH19B	£680.00	LT230T	QDF30KT	£815.00
Hyundai Getz	QDF21B	£680.00	Land Rover / Range Rover / Discovery	QDF41K	£680.00
Isuzu Piazza RWD	QDF4B	£615.00	Land Rover 110 (Salisbury rear axle)	QDF25K	£815.00
Isuzu Impulse / Piazza FWD	QDF2I	£615.00	Land Rover 110 (2002-2010) / Range Rover P38	QDF42K	£680.00
Jaguar saloon / E type (IRS – 4HA)	QDF1W	£815.00	Lotus Elan (English)	QDF5Z/22	£460.00
Jaguar XK/XKR Mk2 (X150 Aluminium body 2006+) S-Type 2003-2008	QDF3W	£POA	Lotus Elan SE Turbo M100	QDF2I	£615.00
Jaguar XK8/XKR Mk1 (X100 Steel body 1996-2006)	QDF5W	£POA	Lotus Elise (PG1)	QDF28K	£575.00
Kia Venga	QDH23B	£615.00	Lotus Elise S2 (Toyota/Aisin BC16)	QDF21E	£615.00
Lamborghini Gallardo Rear	QDH1V	£POA	Lotus Elise SC & Cup (Toyota EC60)	QDF29E	£615.00
Lamborghini Murcielago Front	QDH2V	£POA	Lotus Elite Climax	QDF5K	£575.00
Lamborghini Murcielago Rear	QDH3V	£POA	Lotus Esprit Stevens – S4, V8 (88-04 Renault UN1/369 trans)	QDF5M	£POA
Lamborghini Gallardo Front	QDH4V	£POA	Lotus Esprit Giugiaro – S1,S2,S3 (75-87 Citroën trans)	QDF13H	£POA
Lancia Ypsilon, Musa, Delta MK1 & MK2, Dedra, Lybra	QDH2K	£615.00	Lotus Europa 4-speed (Renault 336 trans)	QDF2X	£615.00
			Lotus Europa 5-speed (Renault 365 trans)	QDF3X	£615.00
			Lotus Europa (2006+)	QDF25B	£615.00
			Lotus Evora (Aisin EA60/BG6)	QDF27E	£680.00
			Maserati Merak (74-82)	QDF13H	£POA
			Mazda Protégé ES 1995-2000 (F-type trans)	QDF5F	£680.00
			Mazda 626 (93-00), MX6, MX3 V6 (92-94), 3 (G-type trans)	QDF6F/23DG	£615.00
			Mazda Protégé LX (90-94), ES (01-03), Protégé 5 (not 99-00) (G-type trans)	QDF6F/23DG	£615.00
			Mazda 3 MPS 2.3 litre Turbo 2WD	QDF7F	£615.00





Mazda MX5 / Miata Mk3 (NC) 2006+ with 100D chassis	QDF9F	<b>£615.00</b>
Mercedes C320 cdi, CLK63 AMG, E55 AMG, E63 AMG	QDF27B	<b>£POA</b>
Mercedes CLK430, CLK55, E55, CL500, SL55	QDF28B	<b>£POA</b>
Mercedes CLK63 AMG, E63 AMG, CL55 AMG, CLS55 AMG	QDF29B	<b>£POA</b>
Mercedes SLK 350, 204 C220d	QDF30B	<b>£POA</b>
Mercedes 500 SLC	QDF5V	<b>£815.00</b>
MG Midget (A series)	QDF5K	<b>£575.00</b>
MGA / MGB (Banjo axle)	QDF15K	<b>£680.00</b>
MGB (Salisbury axle, crown wheel face to bearing 18.5mm)	QDF6KB	<b>£680.00</b>
MGB V8 / MGC (crown wheel face to bearing 13mm)	QDF6KC	<b>£680.00</b>
MGF (PG1 including ZR 1.8 models)	QDF28K	<b>£575.00</b>
MG / MG ZR 105 (MA gearbox)	QDF9H	<b>£575.00</b>
Mini Cooper S R53 & R56 (SVT/Getrag 285) / Mitsubishi Colt CZT	QDF38Z	<b>£575.00</b>
Mitsubishi Eclipse / Talon 4x4, Lancer Evo 1, 2, 3 (centre)	QDH9B	<b>£615.00</b>
Mitsubishi Eclipse / Talon 4x4, Lancer Evo 1, 2, 3 (front) + 2WD 90-92	QDH8B	<b>£615.00</b>
Mitsubishi Eclipse 2WD non turbo + turbo 93-99	QDH7B	<b>£615.00</b>
Mitsubishi Eclipse 2WD non turbo (T350 trans)	QDF3I	<b>£680.00</b>
Mitsubishi Lancer Evo 4, 5, 6, 7 (centre) for crownwheel	QDH11B	<b>£POA</b>
Mitsubishi Lancer Evo 5, 6, 7, 8, 8MR, 9 (front) w/o crownwheel 5-speed non-active centre diff only	QDH12B	<b>£POA</b>
Mitsubishi Lancer Evo 8, 8MR, 9 (centre) for crownwheel 6-speed non-active centre diff only	QDH13B	<b>£POA</b>
Mitsubishi 3000GT 4WD Front (including speedo drive)	QDH16B	<b>£680.00</b>
Mitsubishi Lancer Evo 4, 5, 6, 7, 8, 9, 10 (rear) open diff replacement	QDH18B	<b>£POA</b>
Mitsubishi Lancer Evo 10 (front)	QDH17B	<b>£680.00</b>

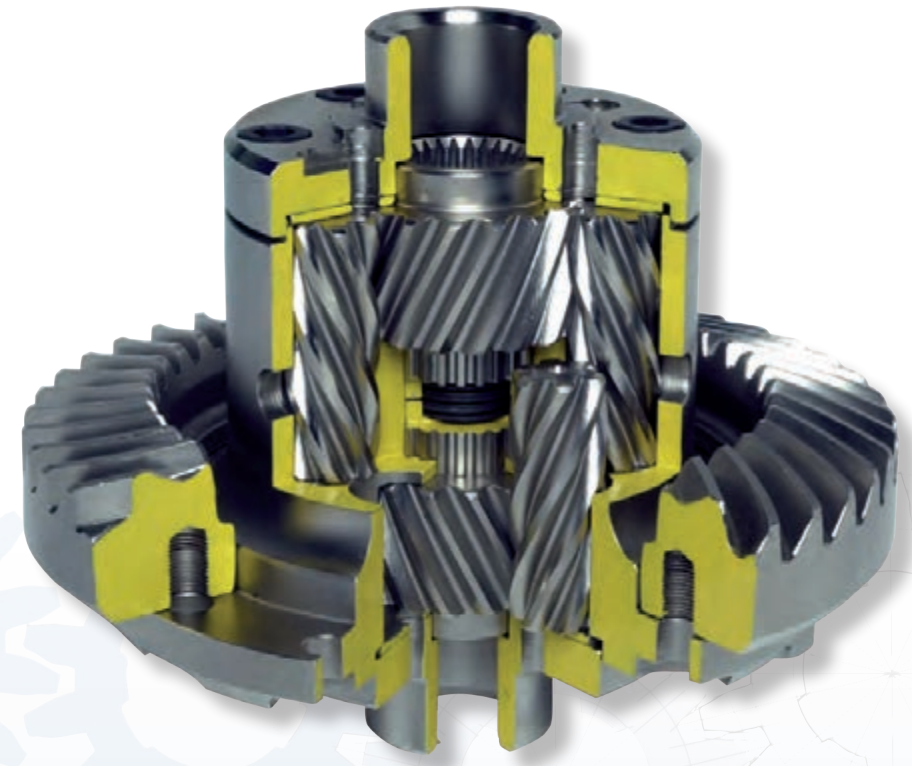

Morgan V8 (7HA)	QDH1M	<b>£680.00</b>
Morgan Plus 8, Roadster, 4/4 Sports (BTR Beam axle), Aero 8 Mk1/2	QDH3M	<b>£680.00</b>
Morgan Aero 8 Mk3+ (Hydratrak replacement BTR-M80)	QDH4M	<b>£680.00</b>
Morris Marina	QDF8K	<b>£575.00</b>
Morris Minor	QDF5K	<b>£575.00</b>
Nissan Almera / Primera / Pulsar SR20 (RS5F32V – viscous diff)	QDF6L	<b>£680.00</b>
Nissan Almera / Primera / Pulsar SR20 (RS5F32A – open diff)	QDF17L	<b>£680.00</b>
Nissan R180 240-280Z (110mm crownwheel)	QDF4L	<b>£680.00</b>
Nissan R180 240-280Z (115mm crownwheel)	QDF5L	<b>£680.00</b>
Nissan R200 280-300Z / 200SX (fits both S13 & S14 – with equal length drive flanges non-viscous)	QDF7L	<b>£680.00</b>

# Quaife ATB differentials

Nissan Maxima	QDF8L	£615.00	Porsche 911 / 915 (18T or 43T) / 924 Turbo (43T)	QDF1Q	£815.00
Nissan Skyline GTR R32/R33/R34 (front)	QDF3L	£POA	Porsche 944 (1986 onwards incl turbo)	QDF4Q	£815.00
Nissan Skyline GTR R32/R33/R34 (rear)	QDF14L	£POA	Porsche 996 6-speed – open diff replacement	QDF7Q	£815.00
Nissan GTR R35 (rear)	QDF15L	£POA	Porsche 996 Turbo, GT2/GT3 (2000-2004) Carrera 2	QDF14Q	£815.00
Nissan GTR R35 (front)	QDF16L	£POA	Porsche Boxster 986 2.5l ('97-'99)	QDF6Q	£815.00
Nissan 350Z – Auto	QDF10L	£680.00	Porsche Boxster S 986 3.2l ('00-'04), 987 3.2l ('05-'06)	QDF7Q	£815.00
Nissan 350Z – Manual	QDF11L	£680.00	Porsche G50 / 996 / 911 '87 on / 930 5-speed '89 on / 993 /968	QDF2Q	£815.00
Nissan 350Z – Viscous replacement	QDF13L	£680.00	Porsche Tiptronic – 993 & 964 only	QDF9Q	£815.00
Nissan R230 300ZX	QDF12L	£815.00	Porsche 968CS	QDF10Q	£815.00
Noble M12 5-speed	QDF20Z	£575.00	Porsche 997	QDF13Q	£815.00
Noble M12 / M400 6-speed	QDF41Z	£575.00	Porsche Cayman S, Boxster S 987 3.4l ('07+)	QDF12Q	£815.00
Opel Manta / GT / Ascona	QDF4B	£615.00	Porsche Cayman & S, Boxster 986/987 (Tiptronic)	QDF15Q	£815.00
Peugeot 106 / 205 (MA gearbox)	QDF9H	£575.00	Porsche Cayman, Boxster 986/987 (2.7l – 5 speed / Audi 01X)	QDF16Q	£815.00
Peugeot 205 / 306 / 309 Gti, 405 Mi16 (BE1,3 & 4 gearbox)	QDF3H	£575.00	Renault Clio 172 / 182 / 5 Turbo (JB3 / Williams JC5)	QDF6M	£895.00
Peugeot 505/504	QDF8H	£615.00	Renault Clio 197 / 200 (TL4) / New RS	QDF9M	£615.00
Pontiac Grand Am (GTP)	QDF18B	£815.00	Renault Clio V6 (PK6)	QDF10M	£895.00
Porsche 911 / 901/ 914 (1969-1974)	QDF5Q	£815.00	Renault Megane 225 (ND0 trans)	QDF8M	£615.00
			Renault 4-speed (Renault 336 trans)	QDF2X	£615.00
			Renault Alpine A310 4cyl 5-speed (Renault 365 trans)	QDF3X	£615.00
			Renault 20/30, 21, 25 / Alpine A310 V6, GTA, A610 (UN1/369)	QDF5M	£POA
			Renault Alpine A110 (Renault 335 trans)	QDF7M	£680.00
			Rover (PG1): 216, 220, 418, 420, 620, 820, Maestro / Montego	QDF28K	£575.00
			Rover SD1	QDF16K	£615.00
			Saab 9000 85-93MY	QDH1J	£POA
			Saab New 900 94MY only	QDH2J	£POA







Saab 9000 94MY and 95MY only	QDH4J	<b>£POA</b>	Subaru BR-Z	QDF28E	<b>£680.00</b>
Saab New 900 95-98MY 9-3 98MY Current	QDH5J	<b>£POA</b>	Talbot Sunbeam	QDF1H	<b>£615.00</b>
Saab 9000 96-98MY	QDH6J	<b>£POA</b>	Toyota Corolla (AE92), Non-supercharged Starlet / Starlet Turbo (EP82/EP91) 4E-FTE	QDF15E	<b>£615.00</b>
Saab 900 Classic 80-93MY	QDH7J	<b>£POA</b>	Toyota MR2 Mk1 (non supercharged) 4A-GE	QDF15E	<b>£615.00</b>
Saab 9-3 Viggen F35 / 9-5 Aero	QDH8J	<b>£POA</b>	Toyota Starlet Turbo (EP71)	QDF16E	<b>£615.00</b>
Saab 9-3 F40 (02-07)	QDH9J	<b>£POA</b>	Toyota MR2 (turbo/supercharged) Mk1 4A-GZE / Mk2 3S-GTE Corolla AE92 supercharged	QDF17E	<b>£615.00</b>
Seat Arosa Sport (02T)	QDF22R	<b>£615.00</b>	Toyota Celica / MR2 Spyder 6-speed (Aisin BC16) 2ZZ-GE / MR2 SW20 (3S-GE)	QDF21E	<b>£615.00</b>
Seat Ibiza (with VW 02A transmission – push in flanges)	QDF8R	<b>£575.00</b>	Toyota 2000 Corolla GT-S 6-speed (Aisin BC16), Scion xB	QDF21E	<b>£615.00</b>
Seat Ibiza (with VW 02J transmission – bolt in flanges)	QDF10R	<b>£615.00</b>	Toyota Scion tC	QDF25E	<b>£615.00</b>
Seat Ibiza (02J-B, 02R, 02S 6-speed) 2004+ c/w bolt kit	QDF26R	<b>£680.00</b>	Toyota GT86 / Scion FR-S	QDF28E	<b>£680.00</b>
Seat Leon (02M)	QDF13R	<b>£615.00</b>	Triumph Dolomite Sprint –does not fit TR2 Lockheed axle	QDF23K	<b>£680.00</b>
Seat Leon FR (197bhp) / Leon Cupra (237bhp) (02Q)	QDF16R	<b>£615.00</b>	Triumph GT6 (modification required if fitting R3.27:1 CWP)	QDF8K	<b>£575.00</b>
Skoda Octavia (with VW 02A transmission – push in flanges)	QDF8R	<b>£575.00</b>	Triumph Herald	QDF8K	<b>£575.00</b>
Skoda Octavia (with VW 02J transmission – bolt in flanges)	QDF10R	<b>£615.00</b>	Triumph Spitfire	QDF8K	<b>£575.00</b>
Skoda Octavia vRS 2.0-litre (02Q)	QDF16R	<b>£615.00</b>	Triumph Stag, TR2, TR3, TR3A, TR4A, TR5, TR6	QDF23K	<b>£680.00</b>
Skoda Fabia / Octavia (02M)	QDF13R	<b>£615.00</b>	Triumph TR7 4-speed	QDF8K	<b>£575.00</b>
Skoda Fabia (02J-B, 02R, 02S 6-speed) 2004+ c/w bolt kit	QDF26R	<b>£680.00</b>	Triumph TR7 5-speed /TR8	QDF16K	<b>£615.00</b>
Subaru Impreza / Legacy (front) (1993-2000)	QDH1Y	<b>£680.00</b>	Triumph Vitesse	QDF8K	<b>£575.00</b>
Subaru Impreza / Legacy (rear) not STi (1993-2000)	QDH2Y	<b>£615.00</b>	TVR All models open replacement (BTR-M76 1997-2005 4 bolt front mount)	QDH3M	<b>£680.00</b>
Subaru Impreza 2001+ All models (front)	QDH3Y	<b>£615.00</b>	TVR Sagaris, Tuscan 2 Hydratrak replacement (BTR-M80 2005+ 3 bolt front mount)	QDH4M	<b>£680.00</b>
			TVR Sagaris, Tuscan 2 open replacement (BTR-M80 2005+ 3 bolt front mount)	QDH5M	<b>£680.00</b>

# Quaife ATB differentials

TVR Cerbera 4.5 & all models Hydratrak option (BTR-M76 1997-2005 4 bolt front mount)

Vauxhall Astra / Kadett (F16 / F18 / F20 / F28-2WD only)

Vauxhall Bearing spacer (F20 TO 2WD F28)

Vauxhall Corsa / Nova (F10 / F13 / F15 / F17)

Vauxhall Cavalier / Calibra (F25)

Vauxhall Vectra / VX220 F23 (Getrag 287)

Vauxhall Calibra F28 4x4 (front)

Vauxhall Astra / Corsa VXR, 1.9 CDTi Astra, Vectra, Zafira (M32)

Vauxhall Astra Bearing for QDF25B

Vauxhall Calibra 4X4 (rear)

Vauxhall F40

Volvo 240

Volvo 850/855 '92-'97, C70 '96-'03, S70, V70 '97-'00, S40, V40 '96-'03 (5-speed – M56)

Volvo S80 '97-'04, S60 '01-'04, V70N '00-'07 (5-speed – M56)

Volvo C30, V50, C70N, S40N '04+, S60 T5, V70N T5 '05-'07 (6-speed – M66)

Volvo S60R 4x4 rear

QDH6M **£680.00**

QDF2B **£575.00**

F2B123 **£25.00**

QDF7B **£575.00**

QDH5J **£575.00**

QDF17B **£615.00**

QDF19B **£615.00**

QDF25B **£615.00**

1801 **£45.00**

QDF26B **£615.00**

QDF21B **£615.00**

QDF8J/27 **£680.00**

QDF12J **£615.00**

QDF12J **£615.00**

QDF13J **£615.00**

QDF11J **£POA**

Volvo S60R 4x4 front

Volvo Amazon (10 bolt crownwheel)

Volvo Amazon (8 bolt crownwheel)

VW Golf Mk1 & 2 / Jetta / Passat / Scirocco (020 – 109mm crownwheel)  
(020 – 111mm crownwheel)

VW Beetle 1302 / 1303 33 / 37 spline (IRS)

VW Golf Mk3 & 4 / Corrado / Jetta / Vento (02A – push in flanges)

VW Beetle swing axle

VW New Beetle / Golf Mk3 & 4 / Jetta / Vento (02J – bolt in flanges)

VW Golf Mk4 2WD 6-speed (02M)

VW Golf Mk4 4WD 6-speed (front – 02M)

VW Golf Rallye 4WD (front – 02C)

VW Golf Mk5 GTi / VW Golf GT TDi / VW Golf 1.4 TSi GT (02Q)

VW Golf MK5 4WD (front – 02Q)

VW Golf DSG 2WD c/w bolt kit (20T brake ring)

VW Golf R Mk6 DSG 4WD c/w bolt kit (25T brake ring)

**VW Golf Mk6 DSG 2WD c/w bolt kit (25T brake ring)**

VW Golf R32 Mk5 DSG 4WD c/w bolt kit (20T brake ring)

VW Polo G40 (085) (1986-1994)

VW Polo GTi / Lupo GTi (02T) 5 & 6 speed 2002+

VW Polo / Golf Mk5 (02J-B, 02R, 02S 6-speed) 2004+ c/w bolt kit

VW Crown wheel bolt fitting kit (02A/02J)

VW Crown wheel bolt fitting kit (02M/02Q)

VW Crown wheel bolt fitting kit (020/02C)

QDF14J **£680.00**

QDF8J/10 **£680.00**

QDF9J **£680.00**

QDF1R/109 **£575.00**

QDF1R/111 **£575.00**

QDF4R **£680.00**

QDF8R **£575.00**

QDF9R **£815.00**

QDF10R **£615.00**

QDF13R **£615.00**

QDF14R **£680.00**

QDF15R **£680.00**

QDF16R **£615.00**

QDF23R **£680.00**

QDF19R **£815.00**

QDF25R **£815.00**

**QDF28R £815.00**

QDF27R **£815.00**

QDF20R **£615.00**

QDF22R **£615.00**

QDF26R **£680.00**

F8R206KIT **£115.00**

1555 **£145.00**

1557 **£115.00**





## Commercial vehicles

Citroën C25	QDF4H	£POA
Fiat Ducato	QDF4H	£POA
Ford P100 (All models)	QDF6Z	£POA
Ford Transit up to 120	QDF13Z	£POA
Ford Transit 140 onwards	QDF11Z	£POA
Ford Transit New Type FWD	QDF20Z	£POA
Ford Transit New Twin & Single	QDF36Z	£POA
Iveco 40–10 Daily	QDH1G	£POA
Isuzu NPS 300	QDF5I	£POA
LDV Pilot 200 series	QDF13K	£POA
LDV Convoy 400 series	QDF9K	£POA
LDV 7.5 Ton Truck (4WD)	QDF27K	£POA
Mercedes 207 / 307 / 310 / 408	QDF1V	£POA
Mitsubishi Fuso FG	QDH20B	£POA
Peugeot Boxer (ME5TU gearbox only)	QDF6H	£POA
Peugeot J5	QDF4H	£POA
Renault Master	QDF1M	£POA
Talbot Express	QDF4H	£POA
Toyota Hi-Lux	QDF20E	£POA
VW LT28 / LT31	QDF2R	£POA
VW LT34	QDF3R	£POA
Volvo Truck	QDF10J	£POA

## Non-commercial vehicles

AC Bristol	QDH1H	£POA
Alvis	QDH3H	£POA
Chrysler PT Turbo	QDH2U	£POA
Ford BC / IB5 Spool	QDF47Z	£POA
Ford Cortina MK3, 4 & 5 (1.3 & 1.6 only)	QDF23Z	£POA
Ford Mustang (Live axle)	QDF35Z	£POA
Ford Mustang 8.8"	QDF29Z	£POA
Ford Sierra 7 1/2" spool	QDF30Z	£POA
Ford Sierra 9" rear incl. flanges (RS500 - 35 spline)	QDF21Z	£POA
Ford Taurus SHO V6	QDF25Z	£POA
Honda (Sealed)	QDF1U/S	£POA
Isuzu Saturn (all S series)	QDF4I	£POA
Lada Samara	QDF2C	£POA
Mazda (100E)	QDF1F	£POA
Mazda 6 V6	QDF8F	£POA
Mendeola HD4	QDF15S	£POA
Mitsubishi Pajero	QDH10B	£POA
Mitsubishi Eclipse GT V6 6-speed (2006+)	QDH15B	£POA
Nissan Sunny	QDF9L	£POA
Suzuki Cultus 4WD / Swift rear	QDF5P	£POA
Toyota Corolla AE86	QDF18E	£POA
Toyota Supra	QDF14E	£POA

# Heavy Duty In-line 6-speed sequential RWD Type 9 replacement gearbox



The Quaife QBE60G heavy duty In-line 6-speed RWD Sequential Gearbox is a direct replacement upgrade for the popular Ford Type 9 transmission and since its launch in 2008 has become the market leader in this sector.

A high strength 80mm shaft centre design with all alloy casings enables QBE60G to handle up to 375bhp, yet it can be installed into a Mk1 / Mk2 Ford Escort or Caterham 7 without transmission tunnel modifications.

QBE60G features a modular gear cluster, allowing easier interchangeability of gear ratios and fewer moving parts, while a drum type sequential gearchange system is allied to an open face dog design on both gear and drive disc. This produces a positive, ultra-fast gearshift – an optional Quaife approved 'intelligent' semi-automatic paddle shift is also available.

Free running gears are supported by needle roller bearings to ensure a robust geartrain, while a choice of ratios and numerous gear lever position options allows customers a wide scope for optimising QBE60G to suit their individual requirements. Weighing just 38 kilos, QBE60G is ideal for rally and race use in Mk1 and Mk2 Ford Escort, Ford Sierra, Caterham, Westfield and numerous rear wheel drive kit cars.

Both helical and straight-cut (spur) gears are available on the QBE60G. The former enables the QBE60G to appeal to 'fast road' customers where gear noise is a critical issue.

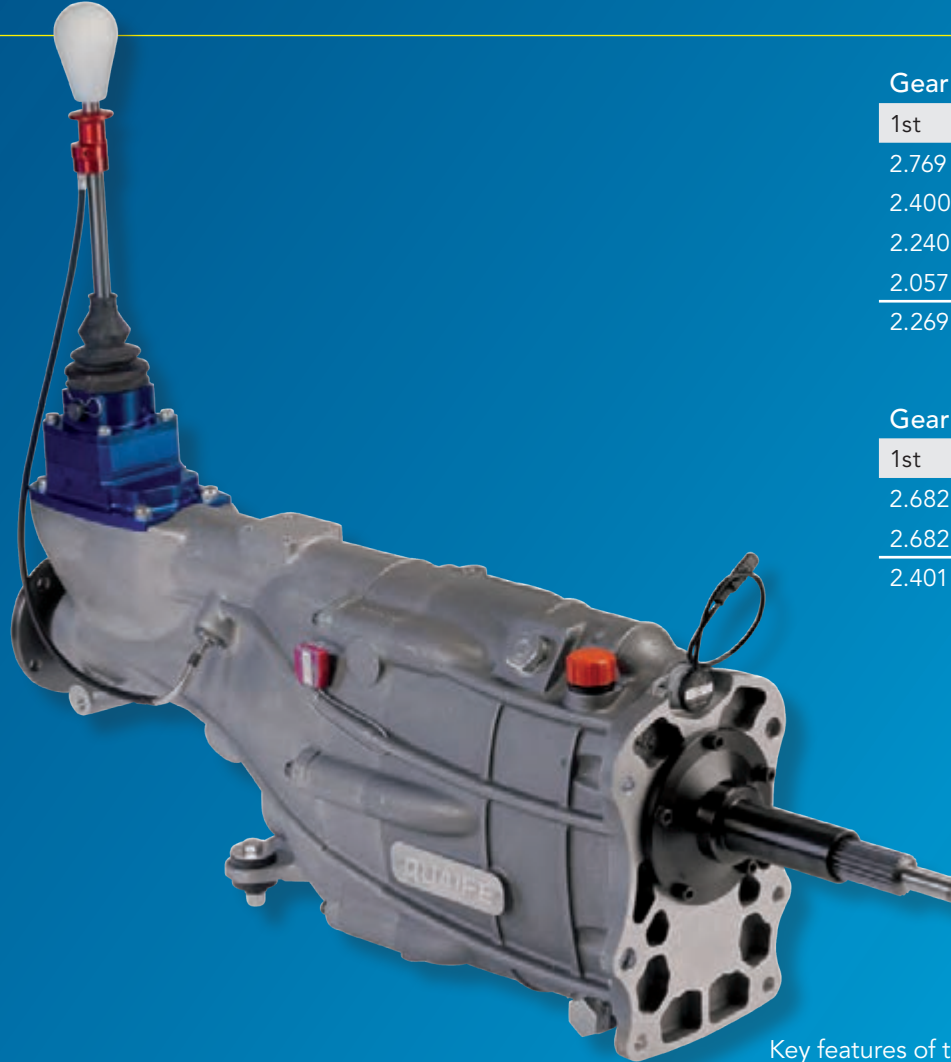

## Gear Ratios (Spur)

1st	2nd	3rd	4th	5th	6th
2.769	2.057	1.579			
2.400	1.840	1.482	1.260	1.104	1.000
2.240	1.694	1.333	1.150	1.000	0.889
2.057					
2.269	1.546	1.217	1.000	0.876	0.811

## Gear Ratios (Helical)

1st	2nd	3rd	4th	5th	6th
2.682	2.000	1.600	1.339	1.157	1.000
2.682	2.000	1.550	1.244	1.000	0.863
2.401	1.660	1.239	1.000	0.866	0.772



Digital Gear Position and Oil Temperature Indicator – optional extra £399.00

Key features of the QBE60G heavy duty six-speed sequential gearbox include:-

- Direct replacement for Ford Type 9 gearbox
- Ultra-fast sequential gearchanges
- Numerous input shaft and gear lever position options
- Weight approximately 38kg
- Direct drive, overdrive or double overdrive
- Over 1000 in use worldwide

Recommended: 1.75l 75W90 GL5 (see page 107) and breather bottle QMBBA, (see page 53)

Part no.

**QBE60G (Spur)**

**£5,775.00**

**QBE60G (Helical)**

**£5,995.00**

### Order now:

Tel: +44 (0)1732 741144

Fax: +44 (0)1732 741555

Email: [info@quaife.co.uk](mailto:info@quaife.co.uk)

Web: [www.quaife.co.uk](http://www.quaife.co.uk)



The QBE69G is a heavy-duty in-line, six-speed sequential gearbox. With 90mm shaft centres this compact unit can transmit up to 750bhp. The QBE69G's technical highlights include an integral oil pump and a modular gear cluster, while a drum type sequential gearchange system is allied to an open face dog design on both gear and drive disc, producing a positive, ultra-fast gearshift.

Straight-cut (spur) or helical gear ratios (including overdrive options) and numerous gear lever position options allow customers wide scope for optimising QBE69G to suit individual requirements.

Key features of the QBE69G heavy duty six-speed sequential gearbox include:-

- Sequential with straight-cut or helical gears, rated to 750bhp
- Bellhousings (not included) include Ford (various), Nissan 350Z, Dodge Viper, Mazda MX-5, Honda S2000, Ford/Chevy V8 / GT86 / SR20 / BMW (see page 5)
- Adaptor kits available for many other vehicles, please call
- Optional gear lever positions to suit individual vehicle applications
- Digital gear position indicator available
- Ground gears are available
- Weight approximately 48kg

### Gear Ratios (Spur)

1st	2nd	3rd	4th	5th	6th	
2.435	1.858	1.494	1.268	1.116	1.000	Spur (1:1)
2.759	2.050	1.565				Spur (1:1)
2.435	1.858	1.494	1.217	1.000	0.870	Spur (o/d)
2.759	2.050	1.565				Spur (o/d)
2.063	1.687	1.357	1.151	1.000	0.901	Spur (o/d)
2.211					0.868	Spur (o/d)
					0.790	Spur (o/d)
2.653	1.745	1.306	1.000	0.850	0.762	Spur (2o/d)

### Gear Ratios (Helical)

1st	2nd	3rd	4th	5th	6th	
2.719	1.994	1.524	1.208	1.000	0.858	Helical (o/d)

Recommended: 1.75l 75W90 GL5 (see page 107) and breather bottle QMBBA, (see page 53)

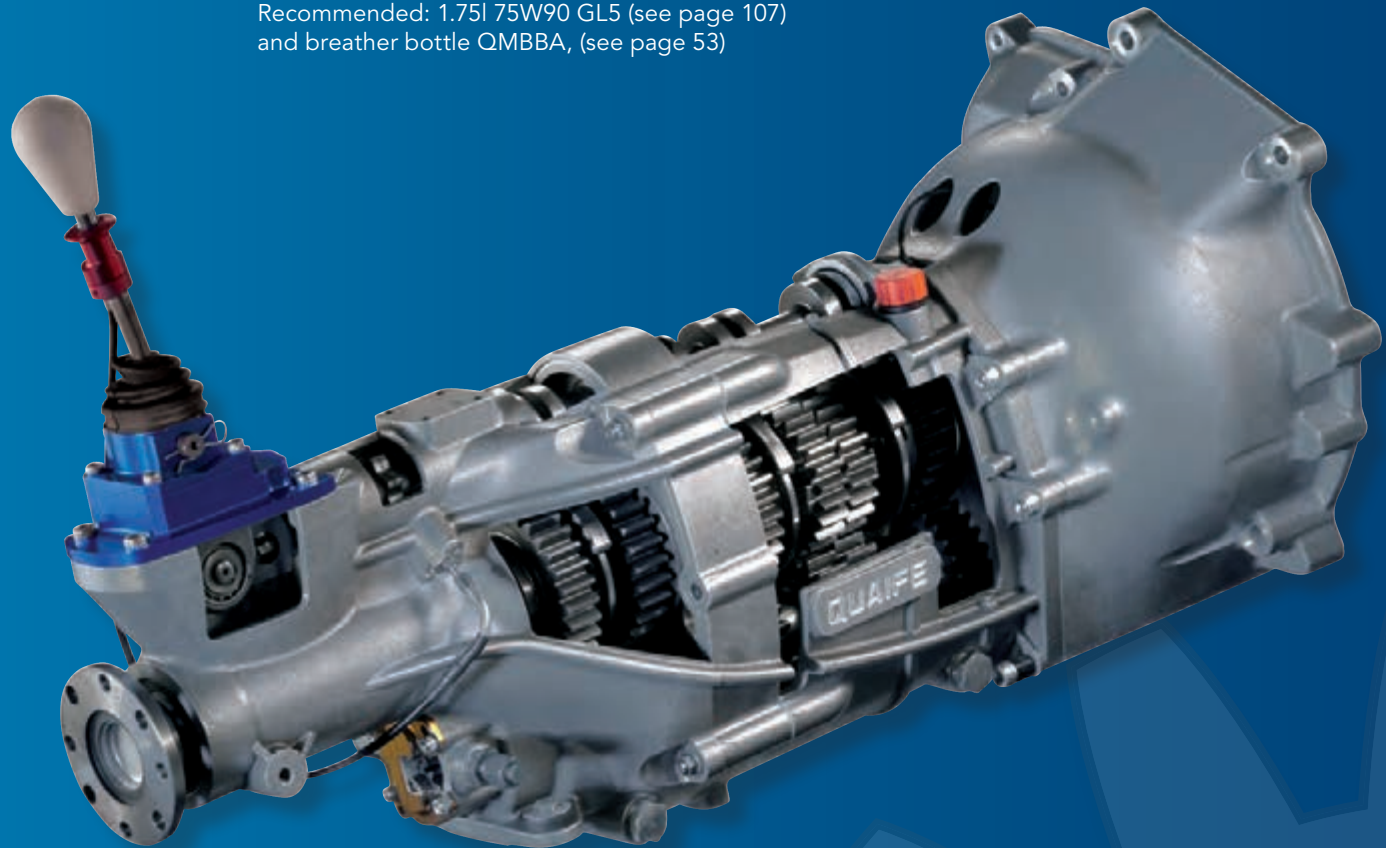

Digital Gear Position and Oil Temperature Indicator – optional extra £399.00

### Order now:

Tel: +44 (0)1732 741144  
 Fax: +44 (0)1732 741555  
 Email: info@quaife.co.uk  
 Web: www.quaife.co.uk

Part no.  
**QBE69G (SPUR)**  
**£7,395.00**  
**QBE69G (HELICAL)**  
**£7,675.00**

### Gear Lever choices for In-line 6-Speed Sequential Gearboxes (included in price)

1. Quaife sequential gearlever – straight  
**QGE60G011**
2. Quaife sequential gearlever – standard  
**QGE60G001**
3. Quaife sequential gearlever – Caterham  
**QGE60G004**
4. Quaife sequential gearlever – long  
**QGE60G007**

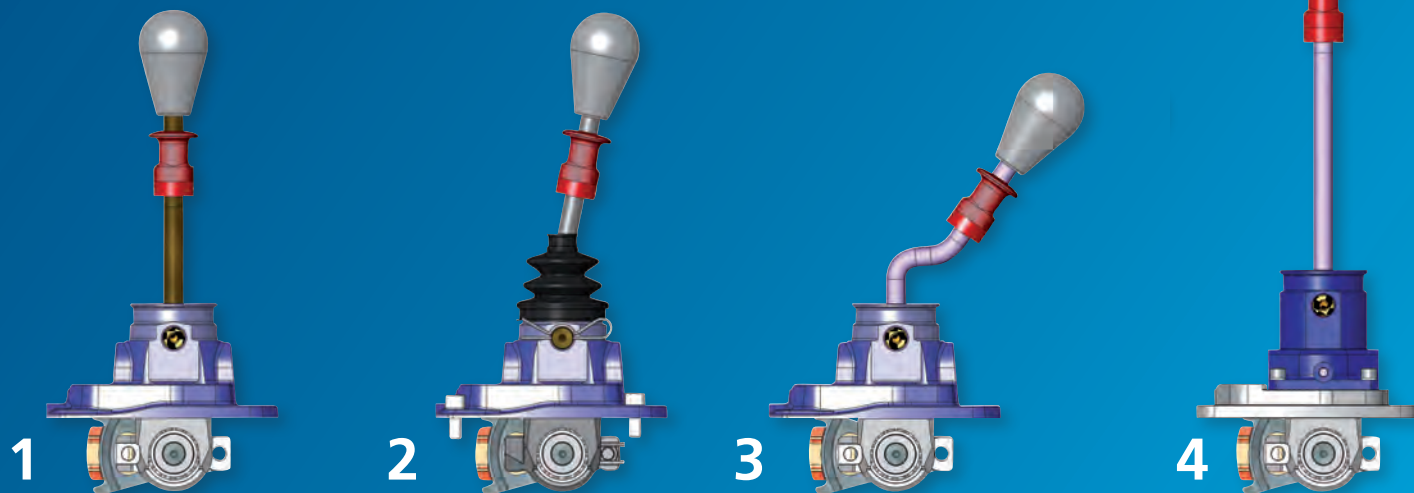

### Optional Gear Levers for In-line 6-Speed Sequential Gearboxes (additional cost)

5. Quaife sequential gearlever – offset  
remote assembly  
**QGE60G002**      £POA
6. Quaife sequential gearlever – extended  
remote assembly  
**QGE60G003**      £POA

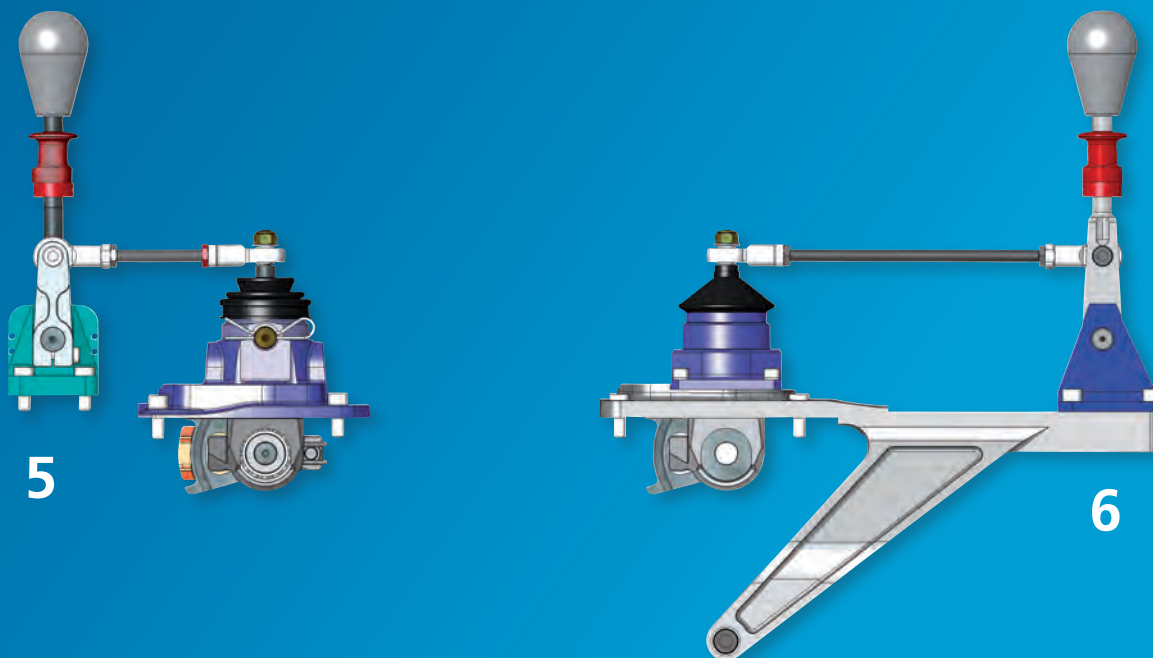

#### Order now:

Tel: +44 (0)1732 741144

Fax: +44 (0)1732 741555

Email: [info@quaife.co.uk](mailto:info@quaife.co.uk)

Web: [www.quaife.co.uk](http://www.quaife.co.uk)



## Paddle Shift Semi-Automatic Gearchange System for QBE60G / 69G Quaife Heavy Duty In-line 6-Speed Sequential Gearbox

Quaife is pleased to present the Geartronics advanced semi-automatic paddle shift system. Designed to work seamlessly with Quaife gearboxes fitted with the QMPAD air actuator and gear change mechanism, the system offers drivers the ability to keep both hands on the wheel while up-shifting on full-throttle and allowing smooth clutchless down-shifts.

With proven reliability in rallying, rallycross and circuit racing, the system is a sophisticated pneumatically powered design, operated by an advanced closed loop gear control unit (GCU) that optimises performance reliability.

The comprehensive package, all available directly from Geartronics ([www.geartronics.co.uk](http://www.geartronics.co.uk)), includes the gear position indicator, GCU and PC set-up software, compressor, accumulator, actuator and valve assembly, twin paddle assembly, throttle blipper, wiring harness and fittings. The system also provides for full on board data logging and integration with current software.

Please ask the Quaife team about this product and how to specify your new gearbox build so that it is ready for this system.

## Digital Gear Position Indicator

- For use with sequential gearbox
- Large display shows gear position
- Lightweight
- Easy to mount
- New: Oil temperature display

**QMLLED £399.00**

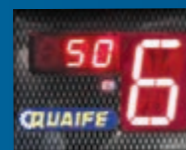

Digital Gear Position and Oil Temperature Indicator – optional extra £399.00

## Bell housings

BMW 4 cylinder N47	<b>E69G1139</b>	<b>£475.00</b>
BMW 6 cylinder N52, S50, S54	<b>E69G1139</b>	<b>£475.00</b>
BMW V8	<b>E69G1139</b>	<b>£475.00</b>
Ford / Chevy V8	<b>E69G2152</b>	<b>£475.00</b>
Ford Cosworth	<b>E6G1176</b>	<b>£475.00</b>
Ford Duratec	<b>D2K102/3</b>	<b>£POA</b>
Ford Mustang (Coyote)	<b>E69G1231</b>	<b>£475.00</b>
Honda S2000	<b>E69G111</b>	<b>£475.00</b>
Mazda MX5	<b>E60G116</b>	<b>£475.00</b>
Land Rover V8	<b>E86G109</b>	<b>£475.00</b>
Nissan SR20	<b>E60G1222</b>	<b>£475.00</b>
Nissan 350Z 2006	<b>E60G2100</b>	<b>£475.00</b>
Nissan 350Z 2007	<b>E60G112</b>	<b>£475.00</b>
Toyota GT86 (BRZ, FR-S)	<b>E60G1220</b>	<b>£475.00</b>



### Order now:

Tel: +44 (0)1732 741144

Fax: +44 (0)1732 741555

Email: [info@quaife.co.uk](mailto:info@quaife.co.uk)

Web: [www.quaife.co.uk](http://www.quaife.co.uk)

# Ford RS200 6-speed Sequential Gearbox



A high-performance, heavy-duty six-speed sequential gearbox designed for the Ford RS200, QBD3X offers a choice of motorsport gear ratios, ultra-rapid, precise shifts and six forward gears. A direct replacement for the RS200's original five-speed, 'H'-pattern, FFD gearbox, QBD3X fits without transmission tunnel modifications and re-uses the Ford's original front and centre differentials, plus propshafts (both the high-speed transmission input and the lower-speed output to the rear differential.)

Reliability with high power engines is assured by QBD3X's use of a 90mm shaft centre format (15mm wider than standard) and Quaife's cutting edge sequential selection mechanism. Alternatively, QBD3X is fully paddleshift compliant with readily available semi-automatic gearshift control systems. QBD3X established its credentials with Pat Doran's successful 2013 Pikes Peak International Hill Climb RS200 and is available with two close-ratio gearsets - a straight cut rally set or a helical-cut road version.

Key technical features of the Quaife QBD3X six-speed sequential gearbox for the Ford RS200 include:

- Two close-ratio gearsets; one with rally suited straight cut gears plus a helical cut road suited version
- 90mm shaft centres to handle over 750bhp
- Direct replacement for original five-speed, 'H'-pattern RS200 FFD gearbox
- Ultra-fast sequential gearshift with semi-automatic paddleshift compatibility
- Optional paddleshift and LED digital gear readout available

## Gear Ratios Straight cut (Spur) Rally

1st	2nd	3rd	4th	5th	6th
2.727	1.929	1.421	1.190	1.043	0.923
2.692	2.000	1.611	1.333	1.125	0.960

## Gear Ratios (Helical)

1st	2nd	3rd	4th	5th	6th
2.917	2.133	1.611	1.238	0.958	0.778

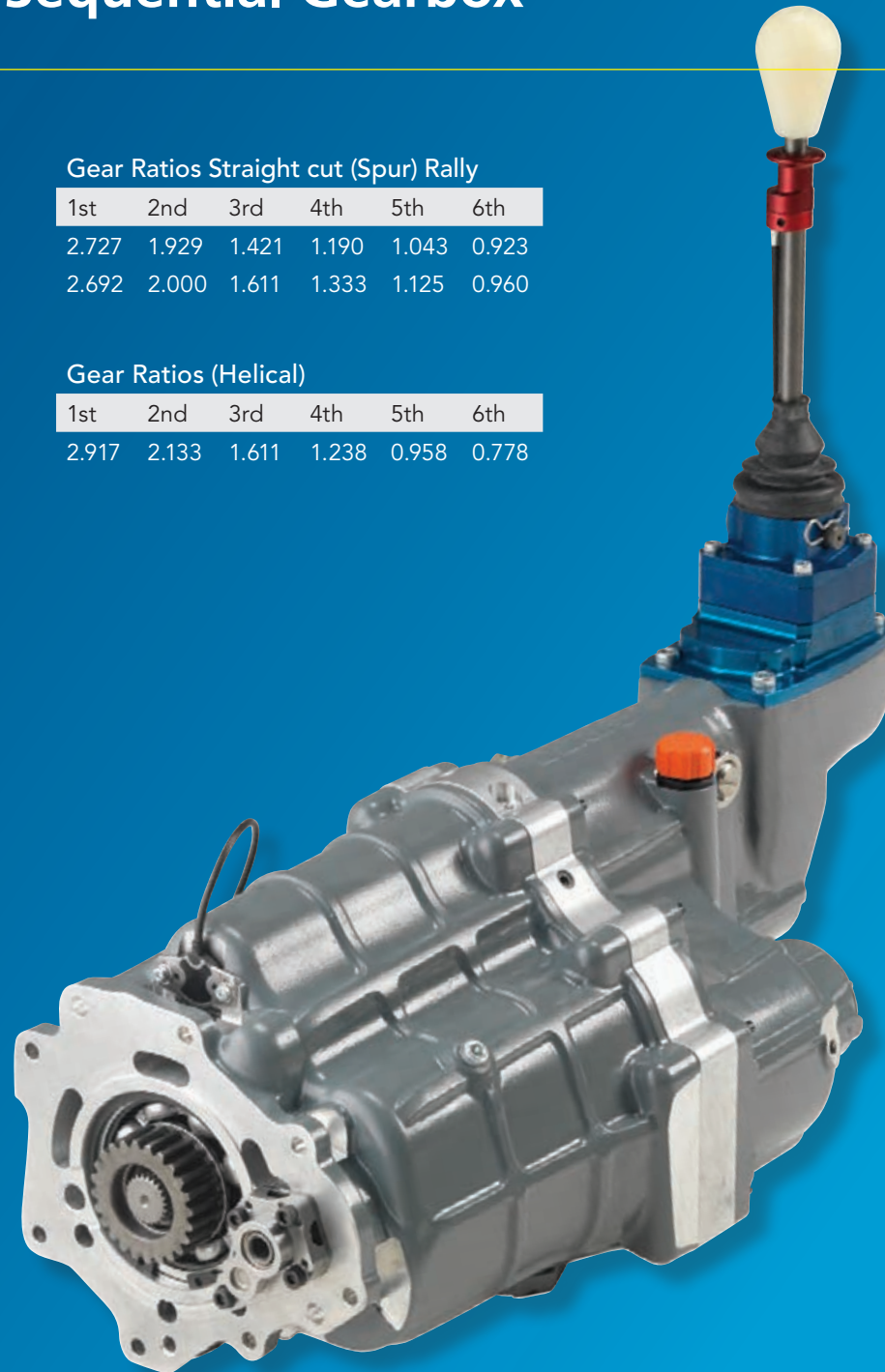

Digital Gear Position and Oil Temperature Indicator  
– optional extra £399.00

Part no.

**QBD3X**

**£14,950.00**

**Ford**

## Order now:

Tel: +44 (0)1732 741144

Fax: +44 (0)1732 741555

Email: [info@quaife.co.uk](mailto:info@quaife.co.uk)

Web: [www.quaife.co.uk](http://www.quaife.co.uk)



The Quaife QBM19Q is an advanced, compact in-line six speed sequential gearbox that sets new industry benchmarks for size, performance and standard levels of equipment. Specified for use in applications up to 1000 bhp, Quaife's patented Quantum technology delivers six speeds from just four pairs of gears, enabling significant reductions in overall size and weight of the complete gearbox, plus a greater spread of gears and reduced rev drops between ratios.

By using the specially designed QBM19Q adapter plate and input flange, the standard Chevrolet Corvette rear differential can be bolted to the QBM19Q gearbox to offer a drop-in solution that replaces the standard H-pattern transmission with a heavy duty 6-speed sequential gearbox rated to 1000 bhp.

Incorporating high strength aircraft specification aluminium casings, a robust 95mm shaft layout and durable wide EN39 steel gears, QBM19Q offers a 6 Kg weight saving compared with the QBE69G. The Quaife camdrum gear change mechanism ensures fast and precise engagement of six optimised close ratio gears that are linked to a digital gear position indicator supplied as standard with this gearbox. In addition, QBM19Q has been designed to be fully paddle shift compatible.

See the Quaife Quantum catalogue for full details of this and our large range of brand new gearboxes and differentials.

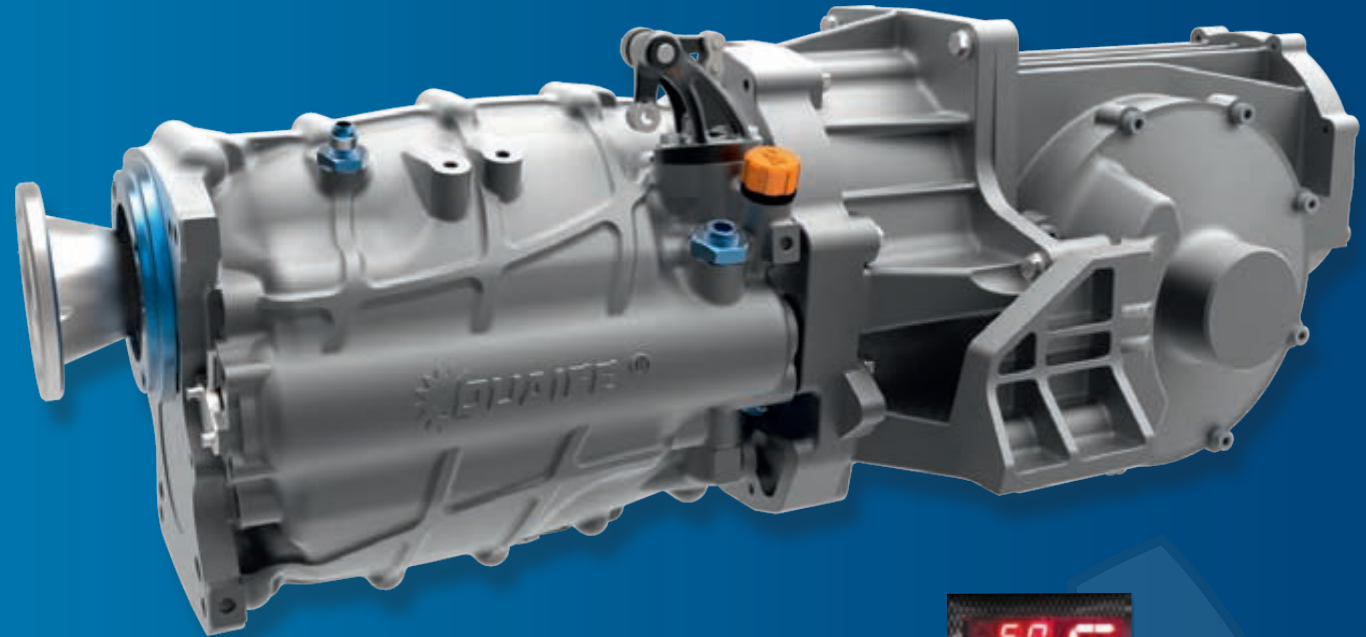

Digital Gear Position and Oil Temperature Indicator – optional extra £399.00

### Gear Ratios Straight cut (Spur) Rally

1st	2nd	3rd	4th	5th	6th
3.044	2.148	1.688	1.417	1.191	1.000
2.517	1.899	1.515	1.326	1.143	1.000

### Gear Ratios (Helical)

1st	2nd	3rd	4th	5th	6th
2.273	1.630	1.186	1.000	0.850	0.717

### £POA

#### Enquire now:

Tel: +44 (0)1732 741144  
 Fax: +44 (0)1732 741555  
 Email: [info@quaife.co.uk](mailto:info@quaife.co.uk)  
 Web: [www.quaife.co.uk](http://www.quaife.co.uk)



Ideal for light and medium weight rear engined / rear wheel drive and mid engined / rear wheel drive vehicles seeking a high performance, robust, modern transaxle design that's been designed to be suited to the demands of motorsport, trackday and fast road use.

The Quaife sequential gear selector layout allows for ultra-fast gearchanges, while 85mm shaft centres deliver a design which enables the QBE61G transaxle to reliably handle power outputs of up to 450bhp. An integral oil pump manages lubrication requirements, while Quaife's use of a hypoid crownwheel and pinion ensures maximum strength and minimum gear noise from the final drive unit.

Customers should note that the QBE61G transaxle gearbox is supplied with a Quaife Automatic Torque Biasing helical gear limited slip differential to maximise traction and optimise overall performance from the package.

Two sets of gear ratios are available from stock, with a choice of straight-cut (spur) or helical tooth form, meaning that QBE61G can be used in road car applications where noise management is a critical issue.

Customers also have a choice of two final drive options.

Key features of the Quaife QBE61G Transaxle gearbox include:-

- Hypoid crownwheel and pinion
- Sequential dog engagement for a fast and precise gear change
- Straight cut or helical options for race and road use
- Quaife ATB differential fitted as standard
- Various bell housings available – see page 23

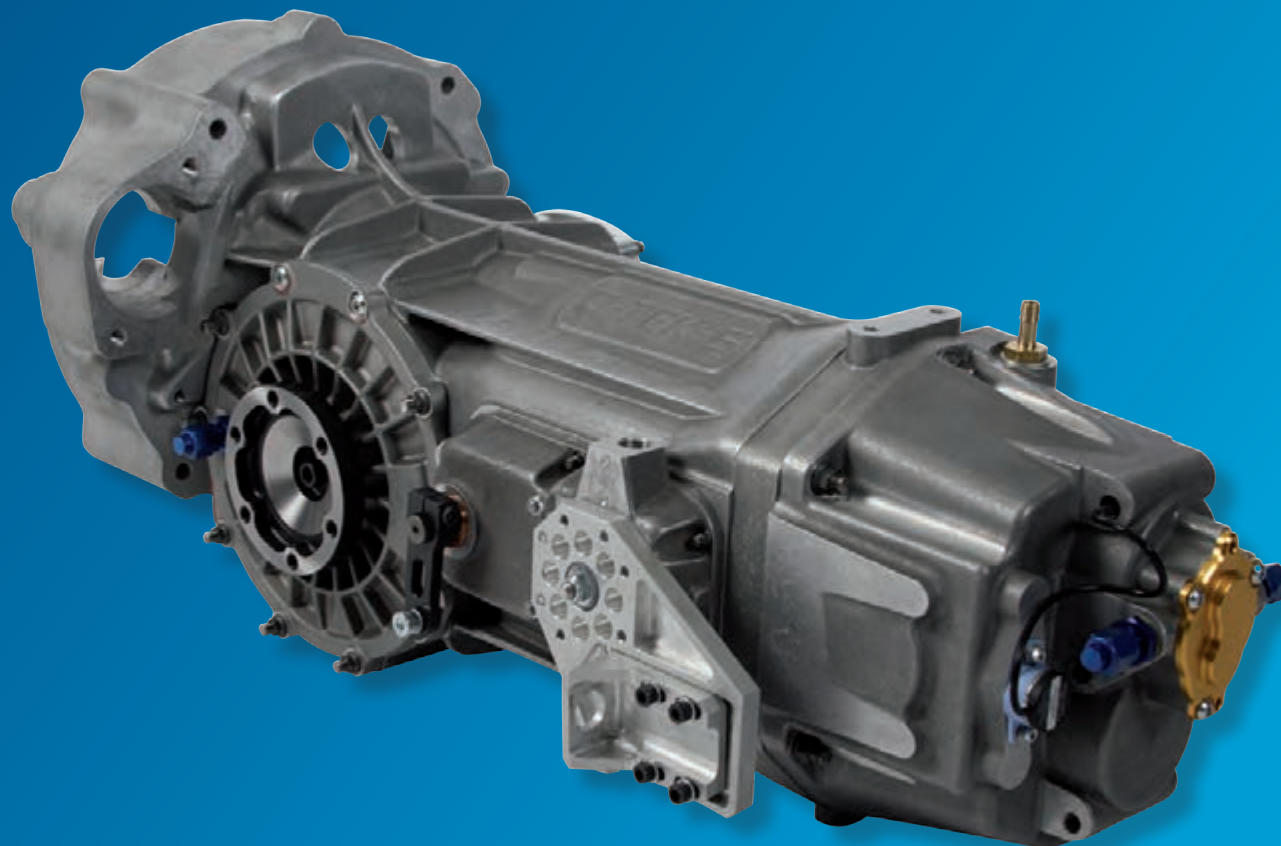

## Gear Ratios

1st	2nd	3rd	4th	5th	6th
2.600	1.933	1.533	1.250	1.043	0.880
3.000	2.000	1.458	1.143	0.921	0.780

## Final Drive Ratio Options

3.750 4.000

Part no.  
**QBE61G**  
**£9,225.00**

## Order now:

Tel: +44 (0)1732 741144  
Fax: +44 (0)1732 741555  
Email: [info@quaife.co.uk](mailto:info@quaife.co.uk)  
Web: [www.quaife.co.uk](http://www.quaife.co.uk)



Digital Gear Position and Oil Temperature Indicator  
– optional extra £399.00

The QBE72G is ideal for smaller, lightweight rear engined / rear wheel drive and mid engined / rear wheel drive vehicles seeking a high performance, robust, modern compact transaxle design suited to the demands of motorsport, trackday and fast road use.

The Quaife sequential selector design offers fast gearchanges, while 85mm shaft centres enable the QBE72G transaxle to transmit up to 450bhp. An integral oil pump manages lubrication, while Quaife's use of a hypoid crownwheel and pinion ensures a robust, quiet, final drive.

The QBE72G transaxle gearbox is supplied with a Quaife Automatic Torque Biasing helical gear limited slip differential to maximise traction and optimise overall performance from the package.

Three sets of gear ratios are available from stock for the QBE72G transaxle. Customers also have a choice of two final drive options.

Key features of the Quaife QBE72G six-speed compact sequential transaxle gearbox include:-

- Weight approximately 53kg
- Hypoid crownwheel and pinion
- Sequential dog engagement for fast and precise gear change
- Quaife ATB differential fitted as standard
- Various diff output flanges available
- Optional digital gear position indicator available

### Gear Ratios

1st	2nd	3rd	4th	5th	6th
2.833	2.071	1.813	1.611	1.444	1.316
		1.733	1.500	1.350	1.200
			1.300	1.136	1.105

### Final Drive Ratio Options

3.750 3.375

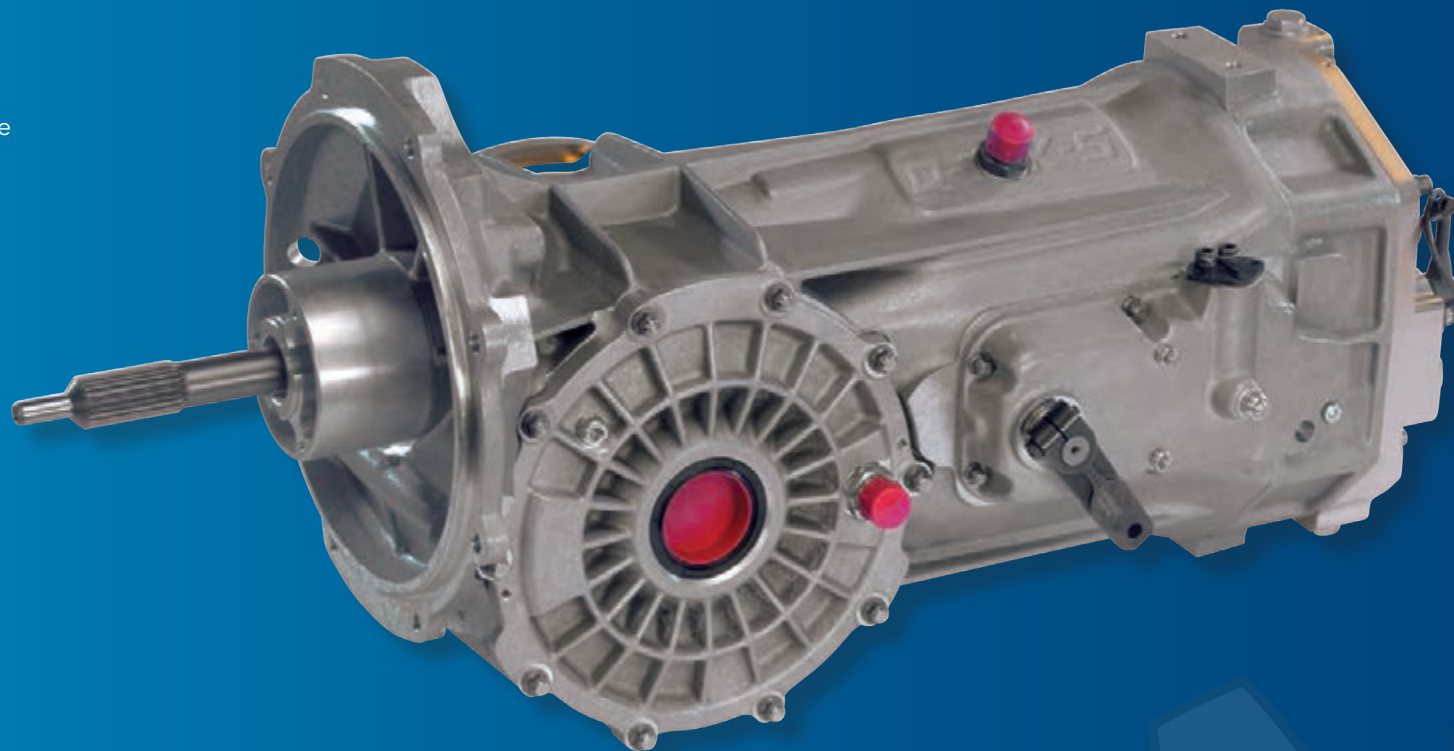

### Bellhousings for QBE61G & QBE72G

Ford OHV RS2000 / Zeta

E18G123

Toyota

E18G1171

Ford Zetec / Focus

E18G1148

Toyota / Lotus Elise

E32G119

Ford Mondeo 4 Cylinder 'Duratec'

Q321

Honda NSX

E32G115

Ford Mondeo (6-Speed)

E52G103

Ford Mondeo V6 (5-Speed)

E42G1018

Ford IB5 Type Rear Starter

Q482

Rover K Series

E18G1144

Volkswagen / Seat / Skoda 4 Cylinder

E18G1142

Vauxhall F20 / F28

E18G121

Peugeot

E18G1139

Kia Large / Mazda 323

E18G1135

Kia Small

E18G1124

Nissan

E18G139

### Order now:

Tel: +44 (0)1732 741144

Fax: +44 (0)1732 741555

Email: [info@quaife.co.uk](mailto:info@quaife.co.uk)

Web: [www.quaife.co.uk](http://www.quaife.co.uk)

Part no.

**QBE72G**

**£POA**

Optional plate type diff  
**£POA**



Quaife designed the QBE62G to provide a modern, updated, robust, direct replacement transmission for the ZF DS-25/2 gearbox as used in the Ford GT40, De Tomaso Pantera, BMW M1 and many other mid-engined supercars.

The fitment, major dimensions, gearchange location and gearchange used on the Quaife QBE62G replicate the ZF DS-25/2 gearbox, while the five speed 'H-pattern' layout and distinctive 'dog-leg' first gear location are also retained to ensure authenticity.

Developed in conjunction with a British-based replica manufacturer, Quaife has ensured that the unit's length allows for easy installation into Ford GT40 type cars, but QBE62G is also suitable for numerous mid-engine replica and kit car applications.

Key engineering details include the use of 85mm shaft centres and a reliable hypoid crownwheel and pinion, which enables the QBE62G transaxle to handle a maximum recommended 500bhp. Helical gears are included with a synchromesh gear selection, minimising gear noise and ensuring everyday usability. Designed for either rod or cable-operated gearchange mechanisms, the QBE62G offers customers a choice of cable or hydraulic clutch release bearing fitments, while a Quaife oil pump is available as an optional extra.

Key features of the Quaife QBE62G 5-Speed, 'H' pattern ZF replacement transaxle gearbox include:-

#### Gear Ratios

1st	2nd	3rd	4th	5th
2.533	1.619	1.200	0.929	0.742

#### Final Drive Ratios

3.500 3.750



- 85mm shaft centres and hypoid crown-wheel and pinion to handle high output engines
- Fitment, major dimensions and gear-change input replicates original ZF DS-25/2
- 5-speed H-pattern with 'dog-leg' 1st, as per original ZF DS-25/2
- Standard GT40 or inverted De Tomaso fitment
- Helical gears and synchromesh gear selection
- Quaife ATB differential included in design

#### Bell housings for QBE62G

Ford / Chevy V8 (GT40)	E62G1-121
Porsche G50	E25G1-45
Ford RS500 Cosworth	E25G1-37
Lotus V8	E25G1-33

Part no.  
**QBE62G**  
**£8,225.00**

#### Order now:

Tel: +44 (0)1732 741144  
Fax: +44 (0)1732 741555  
Email: [info@quaife.co.uk](mailto:info@quaife.co.uk)  
Web: [www.quaife.co.uk](http://www.quaife.co.uk)



A joint development between Quaife and Porsche specialist Parr UK, QBE85G is an updated direct replacement for the factory 997 sequential gearbox. Designed to ensure the optimum blend of performance and ease of installation, race testing has proven that the QBE85G offers exceptional durability compared to its Porsche equivalent.

The QBE85G six-speed sequential transaxle features a large 85mm shaft centre configuration and straight-cut gears, capable of transmitting up to 450bhp. A Porsche Motorsport plate type limited-slip differential is supplied as standard and the unit is lubricated via an internal oil pump that reuses the stock Porsche 997 heat exchanger, which bolts directly to the Quaife QBE85G gearbox. Quaife's use of a hypoid crownwheel and pinion ensures maximum strength and minimum gear noise from the QBE85G's final drive.

The bellhousing design is integrated into the main gearbox casing to suit 996 / 997 / RSR fitment and for use in 997 models, the original Porsche clutch and flywheel are retained. QBE85G is fully compatible with the OEM Porsche 997 motorsport electronics and Porsche wiring loom, avoiding any issues with internal displays or the flatshift ignition cut-off switch.

QBE85G can also be retro fitted to Porsche 996 models (with heat exchanger) – additional parts are required for the installation.

Key features of the Quaife QBE85G Porsche 997 six-speed sequential transaxle gearbox include:

- Major critical dimensions as per Porsche 997 sequential gearbox
- Straight cut gears with sequential dog engagement
- 85mm shaft centres to handle up to 450bhp
- Hypoid crownwheel & pinion
- Porsche Motorsport plate type limited slip differential supplied
- Optional paddle shift system available

Products available through:

**Parr Motorsport Ltd**

Tel: +44 (0) 1293 537911

Email: [motorsport@parr-uk.co.uk](mailto:motorsport@parr-uk.co.uk)

Web: [www.parr-uk.co.uk](http://www.parr-uk.co.uk)



Digital Gear Position and Oil Temperature Indicator – optional extra £399.00



### Gear Ratios

1st	2nd	3rd	4th	5th	6th	
3.167	2.133	1.722	1.421	1.150	0.964	Porsche Base Set
3.167	2.133	1.722	1.421	1.130	0.929	Porsche Option 'A'
2.692	2.000	1.647	1.400	1.200	1.040	Quaife Base Set
2.692	2.000	1.647	1.350	1.130	0.964	Quaife Option 'A'
2.692	2.000	1.647	1.350	1.130	0.929	Quaife Option 'B'
3.545	2.615	2.000	1.647	1.400	1.200	Rally Set

### Final Drive Ratios

3.750 4.000

### Quaife Porsche 997 Plate Differential

The Quaife Porsche 997 plate style limited slip differential is designed to accept standard Porsche Motorsport internal components, making it ideal as a replacement for a broken or damaged Porsche 997 original unit.



Replacement diff body and cover  
QKP2Q £POA

Complete diff assembly  
QDP2Q £POA

Part no.  
**QBE85G**  
**£POA**

The QBE56G/57G/68G universal in-line 5/6-speed rear wheel drive gearboxes are updated direct replacements for the Ford Type 9 gearbox. An 'H'-pattern gearchange, synchromesh or dog engagement, plus a choice of helical or straight-cut (spur) gears provide three road suited, motorsport orientated units.

Retaining the same critical dimensions as the Ford Type 9, the QBE56G/57G/68G gearboxes are easily installed into MK1 / MK2 Escort, Sierra, Caterham etc without transmission tunnel modifications.

The QBE56G/57G/68G use alloy casings and are directly compatible with Ford bellhousings, a 6-bolt fitment can be accommodated with both long and short input shaft options, ensuring a wide range of vehicle fitments.

Needle roller bearings supporting the free running gears and 80mm shaft centres allow QBE56G/57G/68G to transmit up to 375bhp. A choice of gear ratios and two gear lever position options on the five-speed QBE56G/57G units allow scope for customer requirements

Key features of the QBE56G/57G/68G five/six-speed in-line helical H-pattern gearboxes include:-

- Maximum recommended 375bhp
- Direct replacement for Ford Type 9
- Helical or straight-cut gears with H-pattern gearchange
- Synchromesh or dog engagement
- All alloy casings – weighs approximately 35kg



#### QBE56G Gear Ratios (Helical)

1st	2nd	3rd	4th	5th
2.612	1.669	1.224	1.000	0.863
2.400				

#### QBE68G Gear Ratios (Helical)

1st	2nd	3rd	4th	5th	6th
2.682	2.000	1.600	1.339	1.157	1.000
2.612	1.669	1.244	1.000	0.900	0.800

#### QBE57G Gear Ratios (Spur)

1st	2nd	3rd	4th	5th
2.400	1.694	1.333	1.000	0.889
2.240	1.579	1.260		0.923
2.057				

Part no.

**QBE56G**

**£3,700.00**

5 speed synchro

Part no.

**QBE57G**

**£ 4,125.00**

5 speed dog

Part no.

**QBE68G**

**£4,175.00**

6 speed synchro

#### Order now:

Tel: +44 (0)1732 741144

Fax: +44 (0)1732 741555

Email: [info@quaife.co.uk](mailto:info@quaife.co.uk)

Web: [www.quaife.co.uk](http://www.quaife.co.uk)

The Quaife QBE89G is a seven-speed sequential gearbox with ultra-close ratios, ideally suited to the demands of front engine, rear wheel drive cars running small capacity engines with a narrow power band – specifically for Caterham 7, Westfield and similar.

Weighing just 33 kg, QBE89G uses ultra-close gear ratios, a modular gear cluster and an open face dog design on both gear and drive disc to produce positive, fast gearshifts. Needle roller bearings support free running gears to ensure a robust geartrain, while a pair of interchangeable drop gears within QBE89G allows users to tailor overall gearing to allow fine tuning between circuits to optimise top speed or overall acceleration.

For installation into a wide variety of front engine, rear wheel drive vehicles, up to a recommended maximum of 250bhp. QBE89G is designed to be compatible with an optional Quaife approved closed loop semi-automatic paddle gearchange system.

Key features of the Quaife QBE89G seven-speed sequential lightweight universal rear wheel drive gearbox include:-

- Seven ultra-close straight-cut gears
- Ford 4cyl & V6 input shafts available
- Lightweight alloy two piece construction – weighs just 33 kg
- Direct replacement for Ford Type 9 gearbox and QBE60G



Digital Gear Position and Oil Temperature Indicator – optional extra £399.00

### Gear Ratios

1st	2nd	3rd	4th	5th	6th	7th
2.750	2.214	1.800	1.471	1.238	1.043	0.920

### Order now:

Tel: +44 (0)1732 741144  
 Fax: +44 (0)1732 741555  
 Email: [info@quaife.co.uk](mailto:info@quaife.co.uk)  
 Web: [www.quaife.co.uk](http://www.quaife.co.uk)

Part no.  
**QBE89G**  
**£5,125.00**



QBE87G is Quaife's 4x4 six-speed sequential gearbox. With 90mm shaft centres the unit is capable of transmitting up to 750bhp and incorporates an integral in-line transfer assembly. Supplied as standard with a Quaife ATB helical gear limited slip differential, or reconditioned Ford viscous coupling.

Technical highlights include a drum type sequential gearchange system, allied to an open face dog design on both gear and drive disc, producing a positive, fast gearchange.

QBE87G offers a choice of straight-cut (spur) or helical gear ratios (including overdrive options) and the option of either a right or left offset gear lever position, allowing customers a wide scope for optimising the unit to suit their individual requirements.

Key features of the QBE87G heavy duty six-speed sequential gearbox include:-

- Sequential engagement with straight-cut or helical gears, rated to 750bhp
- Ford Sierra Cosworth RS500 bellhousing available from stock – adaptor kits available for many other vehicles
- Digital gear position indicator available
- Both gear and chain drive options available for transfer unit
- Transfer gearing to suit all applications
- For gear lever options see page 18
- Weight approximately 70kg

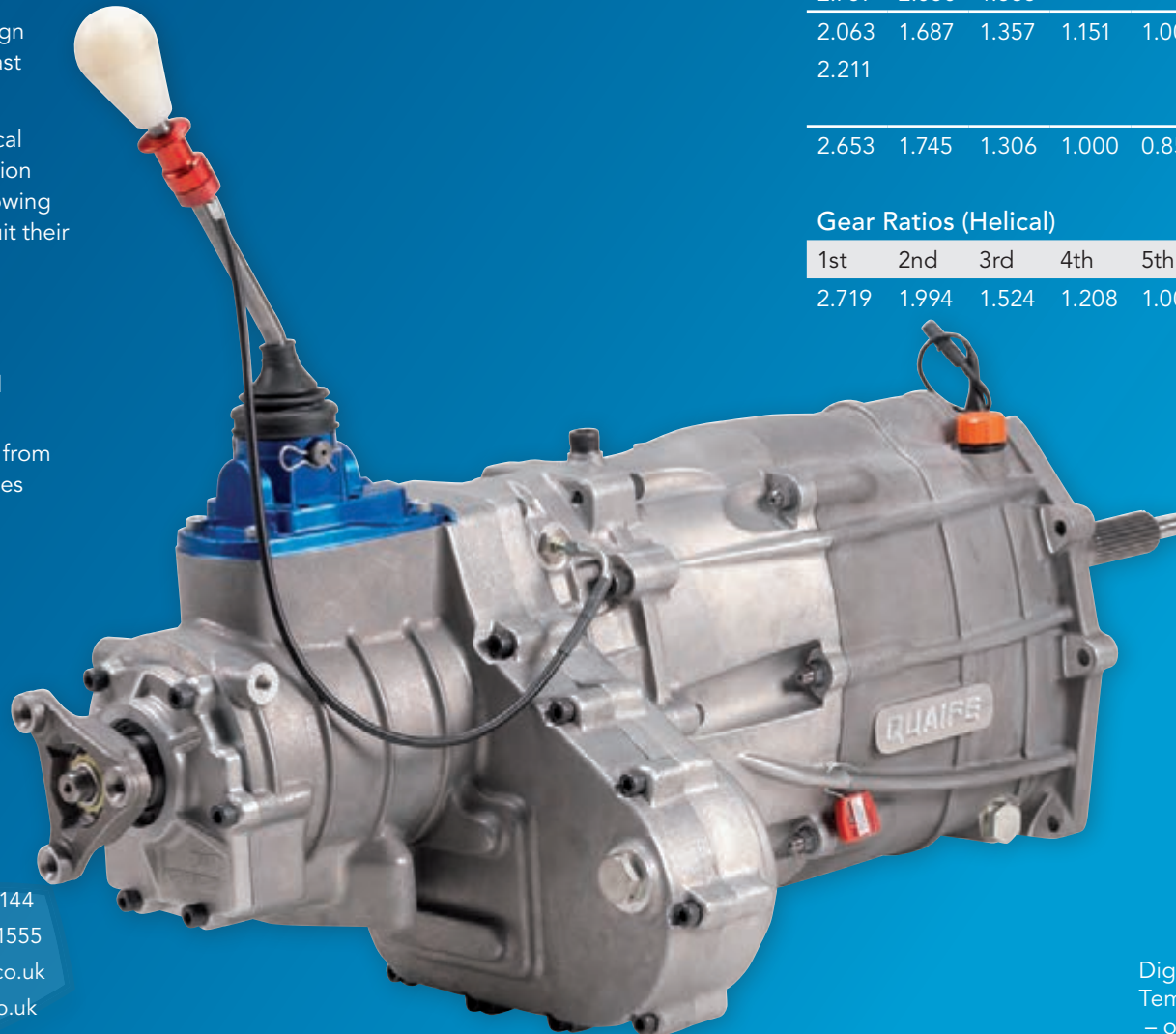

## Gear Ratios (Spur)

1st	2nd	3rd	4th	5th	6th	
2.435	1.858	1.494	1.268	1.116	1.000	Spur (1:1)
2.759	2.050	1.565				Spur (1:1)
2.435	1.858	1.494	1.217	1.000	0.870	Spur (o/d)
2.759	2.050	1.565				Spur (o/d)
2.063	1.687	1.357	1.151	1.000	0.901	Spur (o/d)
2.211					0.868	Spur (o/d)
					0.790	Spur (o/d)
2.653	1.745	1.306	1.000	0.850	0.762	Spur (2o/d)

## Gear Ratios (Helical)

1st	2nd	3rd	4th	5th	6th	
2.719	1.994	1.524	1.208	1.00	0.858	Helical (o/d)

Part no.  
**QBE87G**  
**£9,950.00**

### Order now:

Tel: +44 (0)1732 741144  
Fax: +44 (0)1732 741555  
Email: [info@quaife.co.uk](mailto:info@quaife.co.uk)  
Web: [www.quaife.co.uk](http://www.quaife.co.uk)



Digital Gear Position and Oil Temperature Indicator  
– optional extra £399.00

The QBE86G is a high strength six-speed sequential unit designed for rally raid Land / Range Rover applications where fast gearchanges and reliability are paramount. QBE86G retains the R380 transmission's mounting points and a Land / Range Rover V8 bellhousing is available from stock.

Technical highlights include 90mm shaft centres proven to 750 bhp, wide helical gears and an uprated reverse to suit off-road use. A modular gear cluster and a drum type sequential gearchange system combines with an open face dog design on both gear and drive disc, producing a positive, faster and precise gearchange.

Options include a left hand or right hand gear lever offset and two ratio set choices. The QBE86G retains the original Land / Range Rover LT230 transfer box (not supplied). Compatible with the factory Land / Range Rover centre differential locking mechanism, a Quaife ATB centre differential is also available.

Key features of the QBE86G Land / Range Rover heavy duty six-speed sequential gearbox include:-

- Sequential engagement with straight-cut or helical gears, rated to 750bhp
- Fast and precise gearchange with drum type sequential gearchange mechanism
- Land / Range Rover V8 bellhousing available – plus adaptor kits for many other vehicles
- Digital gear position indicator available
- Retains original propshaft lengths
- Weight approximately 55kg
- Uses standard LT230 transfer (not supplied)

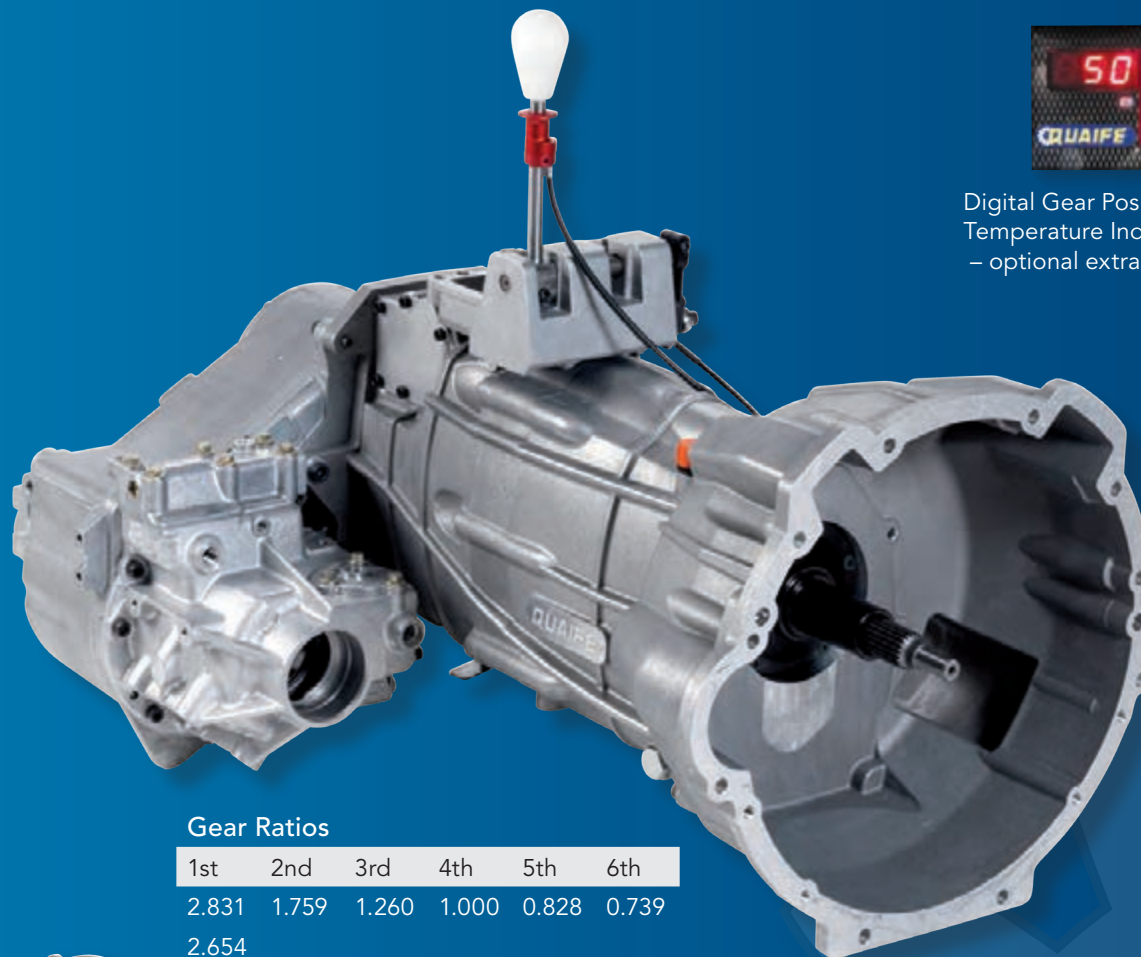
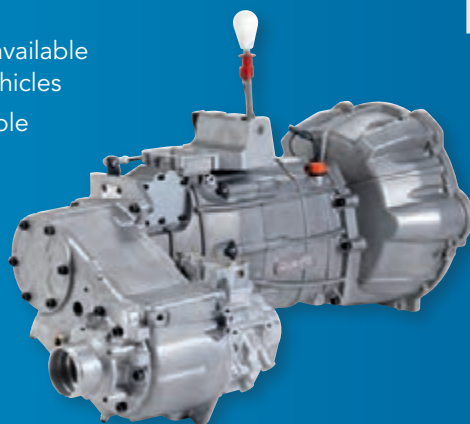

Digital Gear Position and Oil Temperature Indicator – optional extra £399.00

### Gear Ratios

1st	2nd	3rd	4th	5th	6th
2.831	1.759	1.260	1.000	0.828	0.739
2.654					

### Order now:

Tel: +44 (0)1732 741144  
 Fax: +44 (0)1732 741555  
 Email: [info@quaife.co.uk](mailto:info@quaife.co.uk)  
 Web: [www.quaife.co.uk](http://www.quaife.co.uk)

Part no.  
**QBE86G**  
**£POA**

Bell housing – Rover V8  
 E86G1-09 **£475.00**

See page for more options.



# Heavy Duty Nissan Skyline R32-34 GTR sequential six-speed gearbox



QBE91G is a heavy duty six-speed sequential gearbox for the popular Nissan Skyline R32-34 GTR models. Incorporating a Nissan RB26DETT compatible bellhousing and the same 90mm shaft centre design of the proven QBE69G heavy duty gearbox allows the unit to be rated to 750bhp.

Technical highlights include a drum type sequential gearchange system, allied to an open face dog design on both gear and drive disc, producing a positive, fast and precise gearchange. A bespoke rear casing allows the standard Nissan transfer to be fitted, making the QBE91G a direct replacement for the standard box.

A large choice of straight-cut (spur) or helical gear ratios (including overdrive options), allows for a wide scope for optimising the QBE91G unit to suit individual requirements.

Key features of the QBE91G Nissan Skyline R32-34 GTR heavy duty six-speed sequential gearbox include:-

- Sequential engagement with straight-cut or helical gears, rated to 750bhp
- Fast and reliable gearchange with drum type sequential gearchange mechanism
- Nissan RB26DETT bellhousing available from stock – adaptor kits available for many other vehicles, please call
- Digital gear position indicator available
- Uses standard transfer (not supplied)
- Input uses Toyota 1JZ clutch spline for push clutch setup



Digital Gear Position and Oil Temperature Indicator  
– optional extra £399.00

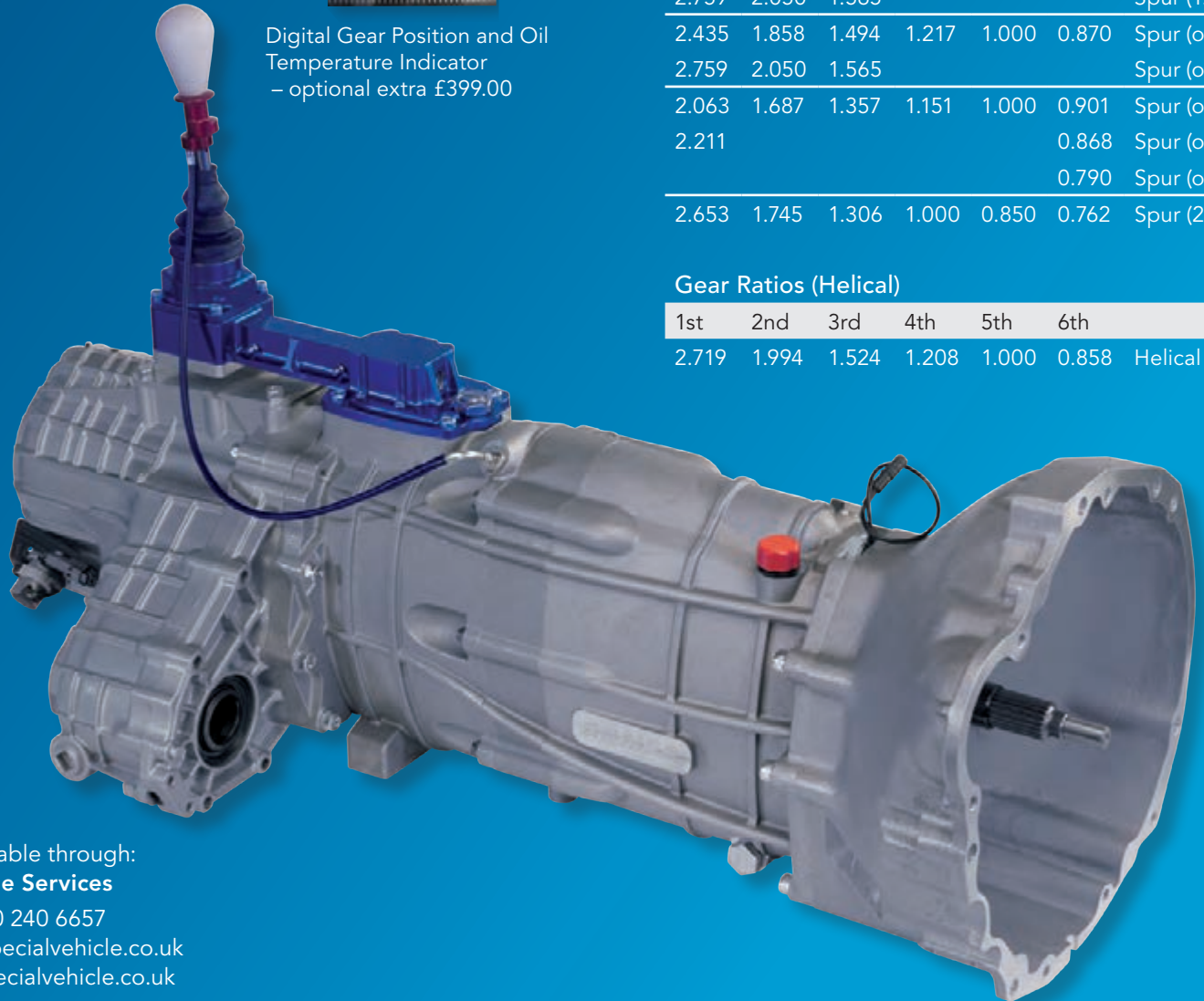

## Gear Ratios (Spur)

1st	2nd	3rd	4th	5th	6th	
2.435	1.858	1.494	1.268	1.116	1.000	Spur (1:1)
2.759	2.050	1.565				Spur (1:1)
2.435	1.858	1.494	1.217	1.000	0.870	Spur (o/d)
2.759	2.050	1.565				Spur (o/d)
2.063	1.687	1.357	1.151	1.000	0.901	Spur (o/d)
2.211					0.868	Spur (o/d)
					0.790	Spur (o/d)
2.653	1.745	1.306	1.000	0.850	0.762	Spur (2o/d)

## Gear Ratios (Helical)

1st	2nd	3rd	4th	5th	6th	
2.719	1.994	1.524	1.208	1.000	0.858	Helical (o/d)



Developed jointly with Radical's Engine department (RPE), QBE81G is a compact, 7-speed transaxle gearbox for mid and rear engine sports cars. Rated to 450bhp, QBE81G is designed around a very short footprint, enabling the entire mass of the gearbox to be contained within the wheelbase of the car.

Technical highlights include 85mm shaft centres, an integral oil pump and Quaife ATB limited slip differential (optional plate type LSD available). Designed to run on Quaife's preferred Geartronics semi-automatic pneumatic paddleshift system (not included) the required air cylinder is bolted to QBE81G's maincase.

QBE81G is offered with a choice of straight-cut (spur) or helical gear ratios and a range of bellhousings – example fitments include the RPE V8 and the four-cylinder Ford Ecoboost engine. QBE81G can potentially be re-engineered as a five or six-speed unit with a higher torque capability should interest arise.

Key technical features of the QBE81G seven-speed compact transaxle gearbox include:-

- Paddleshift gearshift with a choice of straight cut or helical close-ratio gears
- Compact, lightweight design to centralise mass
- A choice of Quaife ATB or plate-style limited slip differential available
- Rated to 450bhp with 85mm shaft centre design
- Also available as 5 or 6-speed for higher power applications

### Gear Ratios (Helical)

1st	2nd	3rd	4th	5th	6th	7th
2.867	2.053	1.609	1.308	1.069	0.875	0.765

### Final Drive Ratios

3.056	3.130	4.067
-------	-------	-------

### Gear Ratios Straight cut (Spur)

1st	2nd	3rd	4th	5th	6th	7th
2.438	1.889	1.500	1.238	1.043	0.897	0.774
2.438	1.889	1.500	1.286	1.115	0.958	0.833

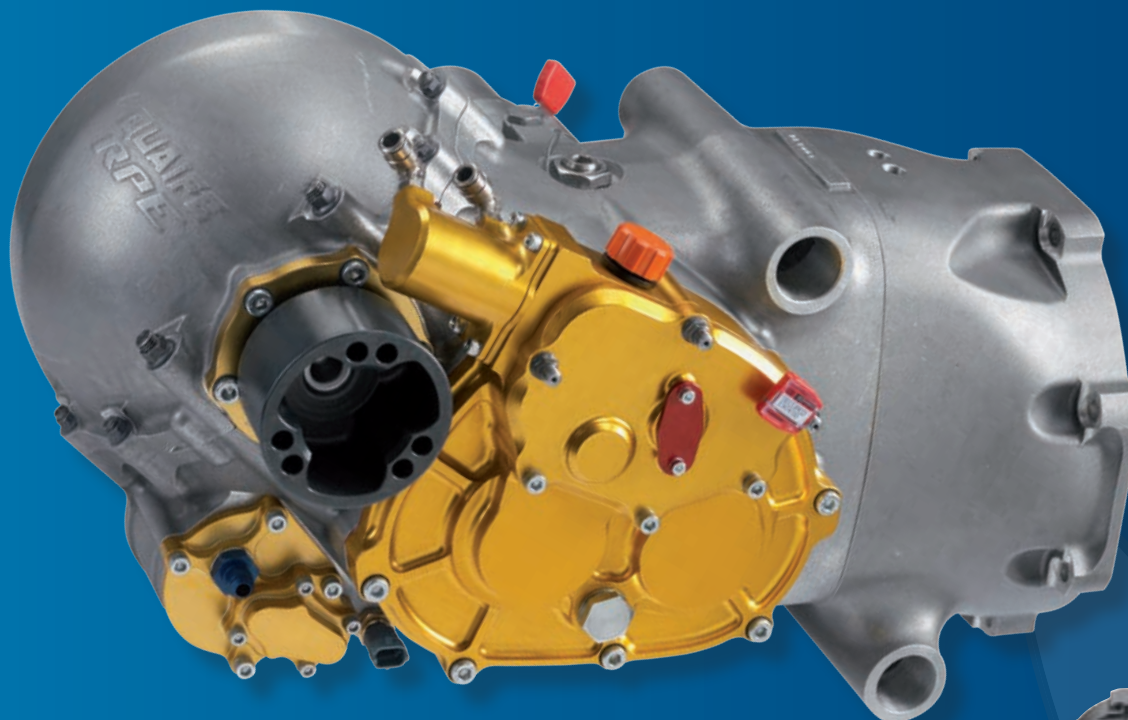

### Order now:

Tel: +44 (0)1732 741144  
 Fax: +44 (0)1732 741555  
 Email: [info@quaife.co.uk](mailto:info@quaife.co.uk)  
 Web: [www.quaife.co.uk](http://www.quaife.co.uk)

Part no.  
**QBE81G**  
**£POA**

Designed as a replacement for the Ford Rocket gearbox used for oval / short circuit racing, QBM1M provides high levels of user configurability in a compact, state-of-the-art package which is rated to transmit up to 250bhp.

An open face four dog design, four straight-cut gears and a barrel style shift mechanism offer ultra-fast gearshifts with a choice of gear lever locations, while the lightweight, short design of QBM1M allows rearward positioning of the engine within vehicles that previously used a short tailcase Rocket gearbox.

QBM1M's drop gear mechanism is secured by circlips and is situated beneath a 'quick change' cover, enabling users to easily alter the overall gearing. Six drop ratio choices, plus a huge range of 1st to 4th gear ratios means QBM1M users can fine tune gearing to suit circuits or even weather conditions in a matter of minutes.

Key technical features of the QBM1M four-speed sequential Rocket-style gearbox with drop gears:

- Fast and precise sequential gearchange with barrel style mechanism
- Wide range of base gear ratio sets and six drop gear options
- Quick change drop gears for easy overall gearing changes
- Compact design with choice of gear lever locations
- Weight approximately 26kg

## Gear Ratios

1st	2nd	3rd	4th
3.31 – 1.600	2.28 – 1.210	2.17 – 0.990	2.05 – 0.790

See table on page 33 for more details

## Drop Gear Ratios

1.370	1.300	1.240	1.180	1.140	1.090
-------	-------	-------	-------	-------	-------

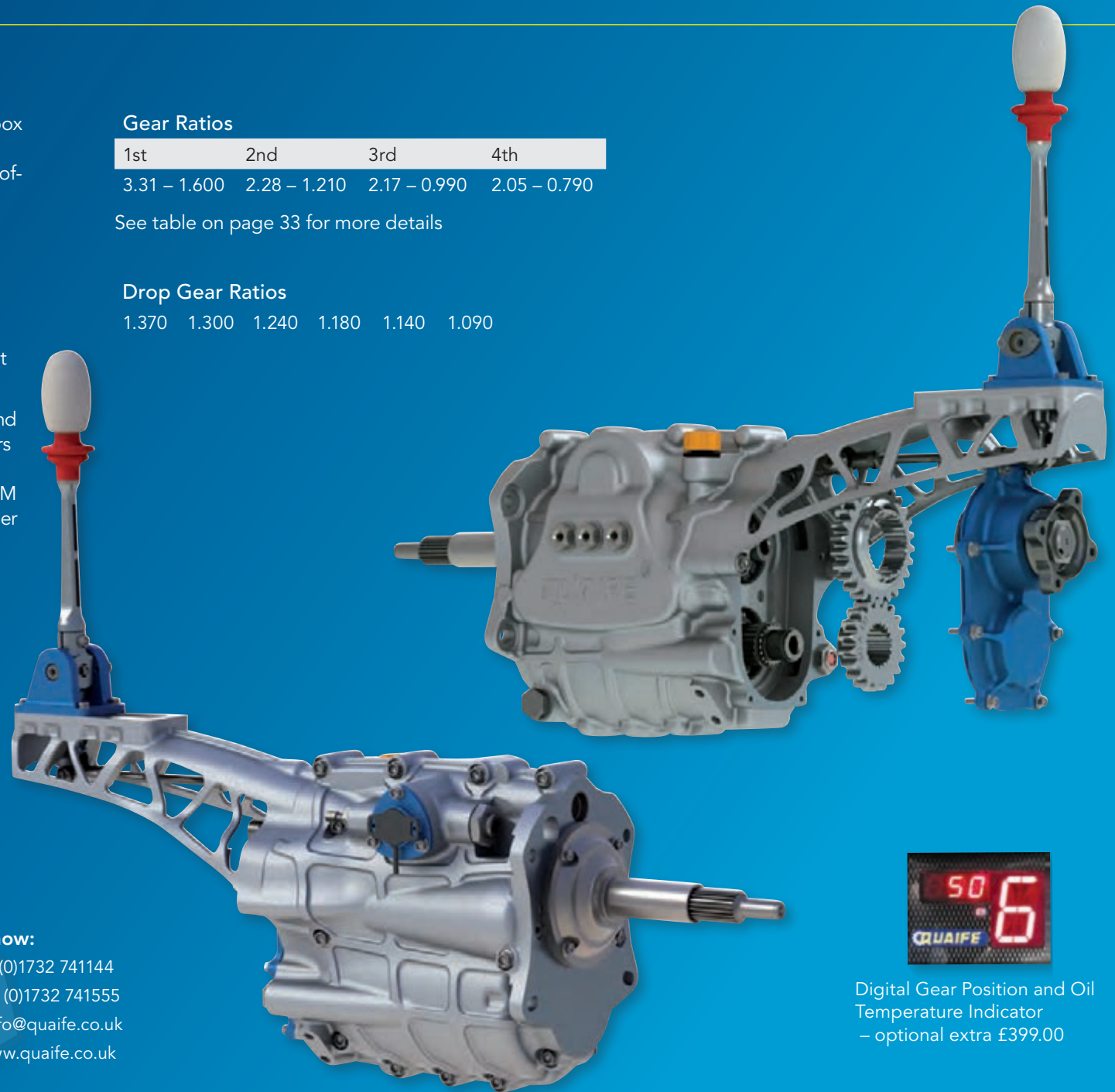

Part no.  
**QBM1M**  
**£3,075.00**

## Order now:

Tel: +44 (0)1732 741144  
Fax: +44 (0)1732 741555  
Email: [info@quaife.co.uk](mailto:info@quaife.co.uk)  
Web: [www.quaife.co.uk](http://www.quaife.co.uk)



Digital Gear Position and Oil Temperature Indicator  
– optional extra £399.00

## 4 Speed Gearbox with gears – Rally, Rally-Cross, Race, UCR & Oval Ratios

			1st GEAR					2nd GEAR				3rd GEAR				4th GEAR				
L/S			29	29	23	28	25	25	22	26	20	27	24	20	20	27	21	21	18	18
M/S(Input)			12	15	13	17	17	15	16	21	18	17	23	21	22	18	26	27	24	25
INPUT	OUTPUT	DROP																		
19	26	1.368	3.307	2.646	2.421	2.254	2.012	2.281	1.882	1.694	1.520	2.173	1.428	1.303	1.244	2.053	1.105	1.064	1.026	0.985
20	26	1.300	3.142	2.513	2.300	2.141	1.912	2.167	1.788	1.610	1.444	2.065	1.357	1.238	1.182	1.950	1.050	1.011	0.975	0.936
21	26	1.238	2.992	2.394	2.190	2.039	1.821	2.063	1.702	1.533	1.376	1.966	1.292	1.179	1.126	1.857	1.000	0.963	0.929	0.891
BASE SET			Ovals	Rally	RallyX	Race	UCR	Ovals	Rally	Race	UCR	Ovals	Rally	Race	UCR	Ovals	All	Option	Option	Option
22	26	1.182	2.856	2.285	2.190	1.947	1.738	1.970	1.625	1.463	1.313	1.877	1.233	1.126	1.074	1.773	0.955	0.919	0.886	0.851
21	24	1.143	2.762	2.210	2.022	1.882	1.681	1.905	1.571	1.270	2.210	1.815	1.193	1.088	1.039	1.714	0.923	0.889	0.857	0.823
22	24	1.091	2.636	2.109	1.930	1.797	1.604	1.818	1.500	1.351	1.212	1.733	1.138	1.039	0.992	1.636	0.881	0.848	0.818	0.785

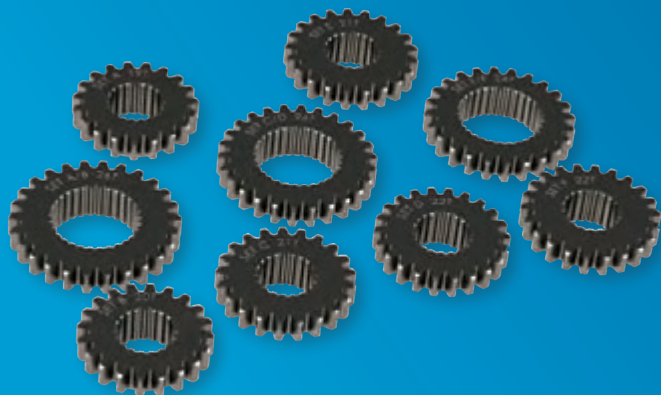

In order to make the new QBM1M gearbox as versatile as possible, we have created a handy drop gear storage case. This kit contains the full set of drop gears, protected by a high-density foam insert, allowing the QBM1M gearbox ratios to be fine tuned according to each event or venue.

The table above shows the extraordinary range of options that the QKM1M drop gear set gives.

Please call or email for more ratio options:  
 Tel: +44 (0)1732 741144  
 Email: info@quaife.co.uk

Part no.  
**QKM1M**  
**£395.00**



QKE38Z is a five-speed sequential gearkit for the IB5 gearbox fitted to the Ford Fiesta, Focus, Puma and Ka Mk1. QKE38Z features a replacement Quaife outer gearbox tailcase which houses five power loss minimising straight-cut, close-ratio gears and a compact, drum-style sequential gearchange mechanism. This combines with an open face dog design to ensure an ultra-rapid, positive sequential gear shift on QKE38Z.

Careful design by Quaife allows the QKE38Z to retain the original IB5 bellhousing half of the transmission casing, plus the stock Ford clutch, differential, driveshafts and mounting points. This enables easy installation of the QKE38Z sequential gearkit into numerous Ford models.

QKE38Z offers a choice of gear ratios sets and seven final drive options suited to motorsport top speed requirements.

A five-speed H-pattern dog engagement gearkit (see page 65) is also available, which features the same ratios as QKE38Z but fits directly into the original Ford IB5 gearbox casing.

Key features of the QKE38Z Ford IB5 five-speed sequential gearkit include:

- Five straight-cut, close-ratio gears with motorsport suited final drive ratios
- Ultra fast sequential gearshift
- Retains stock Ford IB5 clutch, diff, driveshafts and mounts
- Optional LED digital gear position indicator



Digital Gear Position and Oil Temperature Indicator  
– optional extra £399.00



## Gear Ratios

1st	2nd	3rd	4th	5th
2.580	1.870	1.420	1.130	1.040
				0.960

## Final Drive Ratios

3.857 4.083 4.380 4.540 4.690 4.910 5.080

## Order now:

Tel: +44 (0)1732 741144  
Fax: +44 (0)1732 741555  
Email: [info@quaife.co.uk](mailto:info@quaife.co.uk)  
Web: [www.quaife.co.uk](http://www.quaife.co.uk)

Part no.

**QKE38Z**  
**£4,425.00**

**QDF7Z**  
**£575.00**

Additional final drive ratio  
**QRE38Z**      **£625.00**

QKE8J is a 5-speed sequential gearkit for the EP3 and FN2 versions of the Honda Civic Type R as well as the DC5 Integra. Ideally suited to circuit racing, drag racing and rally use it's designed as a direct replacement for the standard six-speed H-pattern Honda transmission.

QKE8J features a replacement Quaife outer gearbox case incorporating an additional support bearing between 4th and 5th gear. A compact, drum style sequential gearchange mechanism and an open face dog design ensure an ultra rapid, positive sequential gear shift.

QKE8J re-uses the original EP3/FN2/DC5 bellhousing half of the transmission casing, enabling the retention of the Honda clutch, differential, driveshafts and mounting points. Wide straight cut (spur) close-ratio gears minimise transmission losses and offer a choice of rally, race or drag race gearing. There is also the choice of a helical set for road and trackday applications.

Key technical features of the QKE8J five-speed Honda EP3/FN2/DC5 sequential gearkit include:-

- Strengthened outer casing and five wider gears
- Ultra fast sequential gearshift with straight cut or helical close-ratio gears
- Retains stock EP3/FN2/DC5 clutch, diff, driveshafts and mounts
- Optional LED digital gear position indicator available
- Optional Quaife ATB for both standard driveshafts (QDF9U) and 28T DSS uprated shafts (QDF17U)



Digital Gear Position and Oil Temperature Indicator – optional extra £399.00



Products available through  
**Momentum Motorsports**  
 Tel: +44 (0)2892 621822  
 Email: [info@momentummotorsport.co.uk](mailto:info@momentummotorsport.co.uk)  
 Web: [www.momentummotorsport.com](http://www.momentummotorsport.com)

### Gear Ratios

1st	2nd	3rd	4th	5th	
3.100	2.067	1.421	1.048	0.870	Drag Set
3.100	2.067	1.611	1.333	1.136	Rally Set
2.417	1.611	1.263	1.000	0.852	Race Set
2.400	1.600	1.261	1.038	0.857	Road/Track Helical Set

### Final Drive Ratios

4.143 4.357 4.750 5.273 5.454 5.818  
 4.750 Helical

PLEASE NOTE: The Quaife QKE8J package includes the new transmission housing, gear lever and cable

Coming soon for 2015,  
 Honda B-Series gear kit

Part no.  
**QKE8J**  
**£POA**

Additional final drive ratio  
 QRE8J **£POA**



QKE5U is a 5-speed sequential gearkit for the 2010 onwards Kia Venga. Designed for the successful 'Kia Green Scout Cup' single make circuit racing series in Italy. The QKE5U is a direct replacement for the standard five-speed H-pattern Kia transmission.

QKE5U features a replacement Quaife outer gearbox tailcase which houses five power loss minimising straight-cut, close-ratio gears operated by a compact, drum style sequential gearchange mechanism with an open face dog design ensures an ultra rapid with a sequential gear shift.

Clever design by Quaife allows QKE5U to retain the original Kia bellhousing half of the transmission casing, plus the stock Kia clutch, differential, driveshafts and mounting points. This enables easy installation of the QKE5U gearkit into the production Kia Venga.

Key technical features of the QKE5U five-speed Kia Venga sequential gearkit include:-

- Five straight-cut, close-ratio gears with circuit suited final drive ratio
- Ultra fast sequential gearshift
- Retains stock Kia Venga clutch, diff', driveshafts and mounts
- Quaife ATB differential available
- Digital gear position indicator available

#### Gear Ratios

1st	2nd	3rd	4th	5th
3.200	2.231	1.800	1.471	1.211

#### Final Drive Ratios

3.733



Digital Gear Position and Oil Temperature Indicator  
– optional extra £399.00

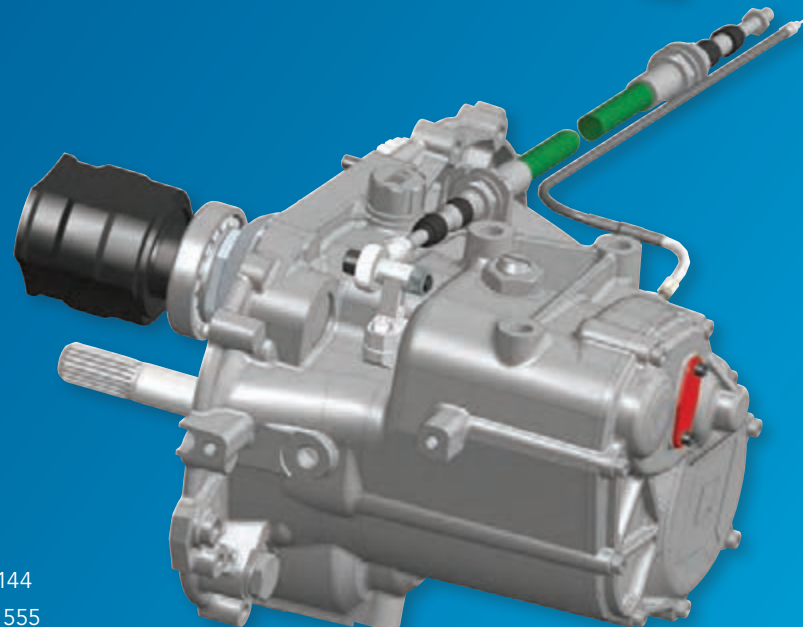
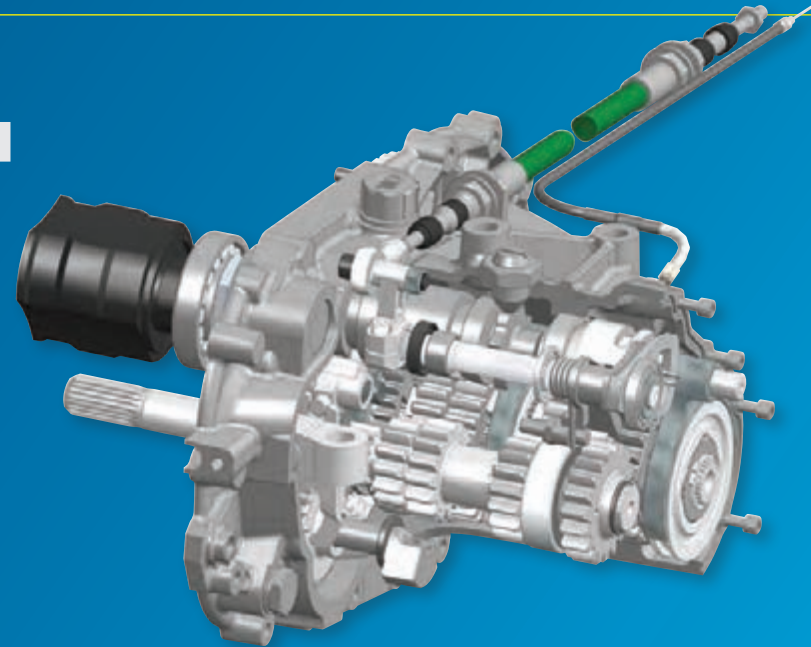

Part no.

**QKE5U**

**£4,425.00**

**QDH23B**

**£615.00**

Additional final drive ratio  
**QRE5U £625.00**

#### Order now:

Tel: +44 (0)1732 741144

Fax: +44 (0)1732 741555

Email: [info@quaife.co.uk](mailto:info@quaife.co.uk)

Web: [www.quaife.co.uk](http://www.quaife.co.uk)

PLEASE NOTE: The Quaife QKE5U package includes the new transmission housing, gear lever and cable



Quaife's popular and successful six-speed sequential gearkit package is now available to boost the performance of the new 1.6-litre 1ZR-FAE engined versions of the Lotus Elise, Elise CR and Lotus Cup models using the EC60 gearbox. A direct replacement for the standard six-speed 'H'-pattern Toyota transmission, the QKE11E six-speed sequential gearkit package includes a specially strengthened outer gearbox casing and sequential gearchange mechanism, which features a compact, drum style design for an ultra rapid gear shift.

The Quaife QKE11E six-speed sequential gearkit uses the bellhousing half of the EC60 gearbox casing, allowing the Toyota clutch, differential, driveshafts and mounting points to be retained. QKE11E features power loss reducing straight cut, close-ratio gears with a choice of final drive ratios to optimize overall gearing for motorsport use, enabling drivers to maximize performance from the 1.6-litre Toyota 1ZR-FAE powerplant. QKE11E is also fully paddleshift compliant with readily available semi-automatic gearshift control systems.

Key technical features of QKE11E include:-

- Strengthened gear casing and stock mounting points
- Ultra fast sequential gearshift with straight cut, close-ratio gears
- Retains stock Toyota 1ZR-FAE clutch, diff', driveshafts and mounts
- Optional LED digital gear readout available
- Optional ATB differential (QDF29E) available

### Gear Ratios Straight (Base Set)

1st	2nd	3rd	4th	5th	6th
3.500	2.545	2.000	1.600	1.333	1.143

### Final Drive Ratios

3.176 3.400

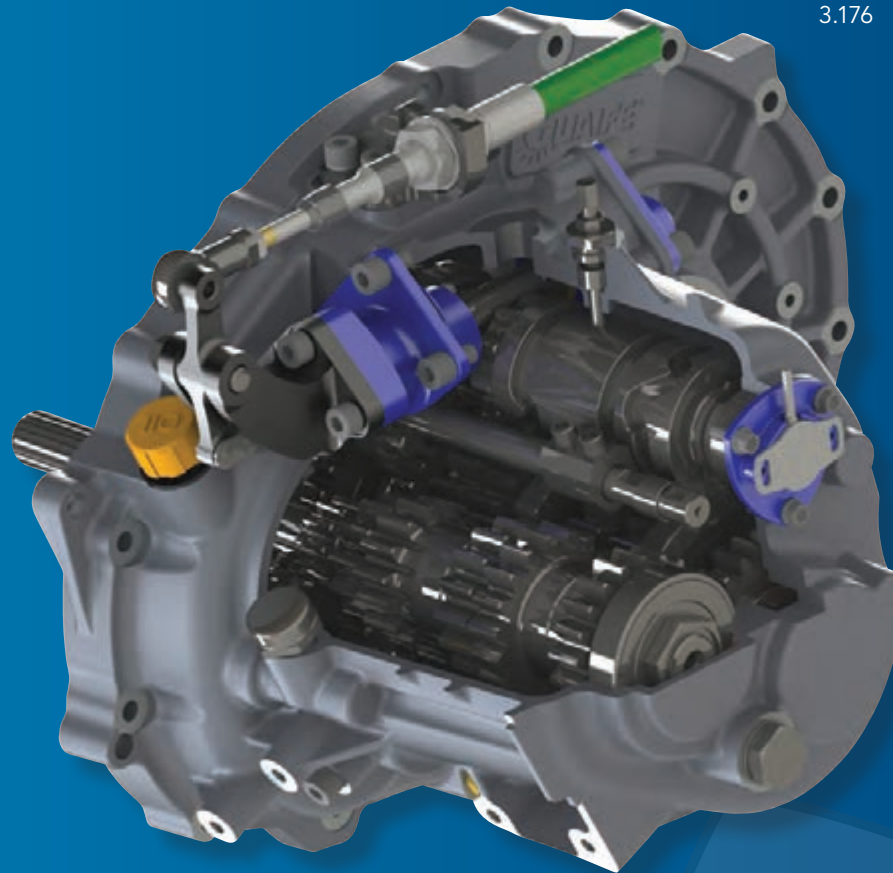

Digital Gear Position and Oil Temperature Indicator  
– optional extra £399.00



Lotus Toyota

Part no.

**QKE11E**

**£POA**

**QDF29E**

**£615.00**

### Order now:

Tel: +44 (0)1732 741144

Fax: +44 (0)1732 741555

Email: [info@quaife.co.uk](mailto:info@quaife.co.uk)

Web: [www.quaife.co.uk](http://www.quaife.co.uk)

PLEASE NOTE: The QKE11E package includes the new Quaife transmission housing, gear lever and cable.

The QKE9E six-speed sequential gearkit is purpose designed for the 2ZZ-GE engine Lotus Elise, Toyota MR2 Spyder, Celica and Corolla models, transforming these sportscars' performance. A direct replacement for the standard six-speed H-pattern Toyota transmission, the QKE9E six-speed sequential gearkit package includes a specially strengthened outer gearbox casing and sequential gearchange mechanism, which features a compact, drum style design for an ultra rapid gear shift.

QKE9E utilises the original bellhousing half of the casing, allowing the retention of the Toyota clutch, differential, driveshafts and mounting points. The QKE9E offers optimised gearing with a choice of five shorter overall final drives and two sets of close-ratio intermediate gears with a straight cut tooth form.

These design elements enable Quaife to minimise transmission power losses and allow drivers to easily keep the 2ZZ-GE engine working in its power band, while delivering a top speed more suited to the needs of competition.

Key technical features of QKE9E include:-

- Strengthened gear casing and stock mounting points
- Fast and precise gearchange with straight cut, close-ratio gears
- Retains stock Toyota 2ZZ-GE clutch, diff, driveshafts and mounts
- Optional Quaife ATB available

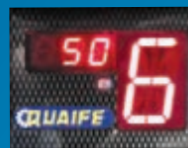
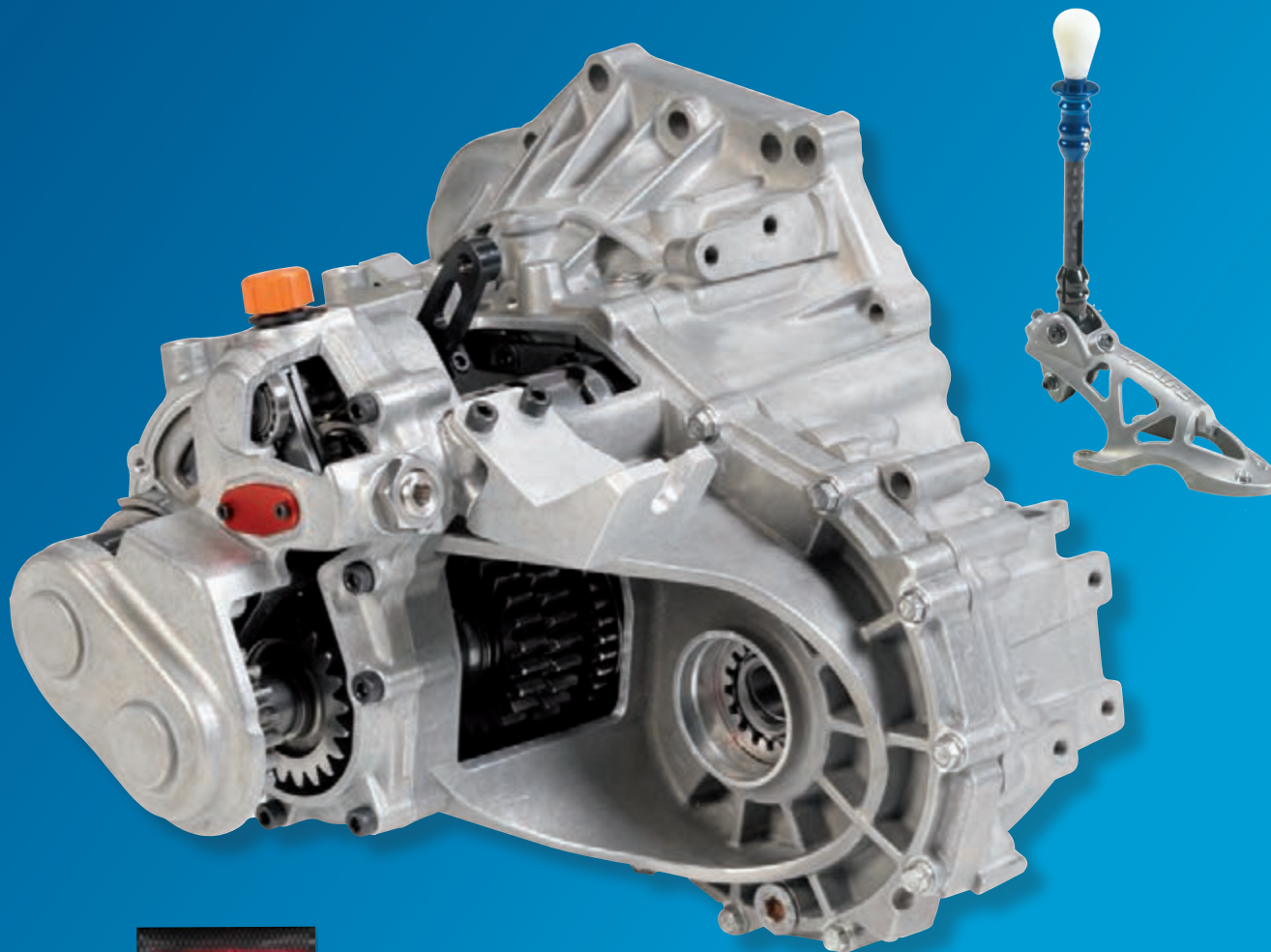

Digital Gear Position and Oil Temperature Indicator  
– optional extra £399.00

#### Gear Ratios

1st	2nd	3rd	4th	5th	6th
2.545	1.929	1.563	1.333	1.167	1.050
3.200	2.250	1.647	1.368	1.143	0.957

#### Final Drive Ratios

3.733	3.857	4.143	4.417	5.000
-------	-------	-------	-------	-------

Toyota

Part no.  
QKE9E  
**£4,425.00**

QDF21E  
**£615.00**

Additional final drive ratio  
QRE9E **£625.00**

#### Order now:

Tel: +44 (0)1732 741144

Fax: +44 (0)1732 741555

Email: [info@quaife.co.uk](mailto:info@quaife.co.uk)

Web: [www.quaife.co.uk](http://www.quaife.co.uk)

PLEASE NOTE: The Quaife QKE9E package includes the new transmission housing, gear lever and cable



QKE10R delivers fast and precise gearchange technology for owners of Lotus Elise / Exige models using the PG1 gearbox. QKE10R features a replacement Quaife outer gearbox tailcase which houses six power loss minimising straight-cut, close-ratio gears and a compact, drum-style sequential gearchange mechanism. This combines with an open face dog design to ensure an ultra-rapid, positive sequential gear shift on QKE10R.

QKE10R retains the original PG1 bellhousing half of the transmission casing, plus the stock Lotus clutch, differential, driveshafts and mounting points. This enables easy installation of the QKE10R sequential gearkit into numerous Lotus models and potentially the MGF and MG ZR / ZS.

QKE10R is supplied with gear ratios suited to motorsport requirements and three final drive options to optimise top speed for the needs of competition.

Key features of the QKE10R Lotus Elise / Exige PG1 six-speed sequential gearkit include:

- Six straight-cut, close-ratio gears with motorsport suited final drive ratios
- Fast and precise sequential gearchange
- Retains stock Lotus Elise / Exige clutch, diff, driveshafts and mounts
- Optional Quaife ATB and LED digital gear position indicator available

### Gear Ratios

1st	2nd	3rd	4th	5th	6th
2.583	2.071	1.688	1.412	1.200	1.048

### Final Drive Ratios

3.923	4.214	4.462
-------	-------	-------



Digital Gear Position and Oil Temperature Indicator – optional extra £399.00

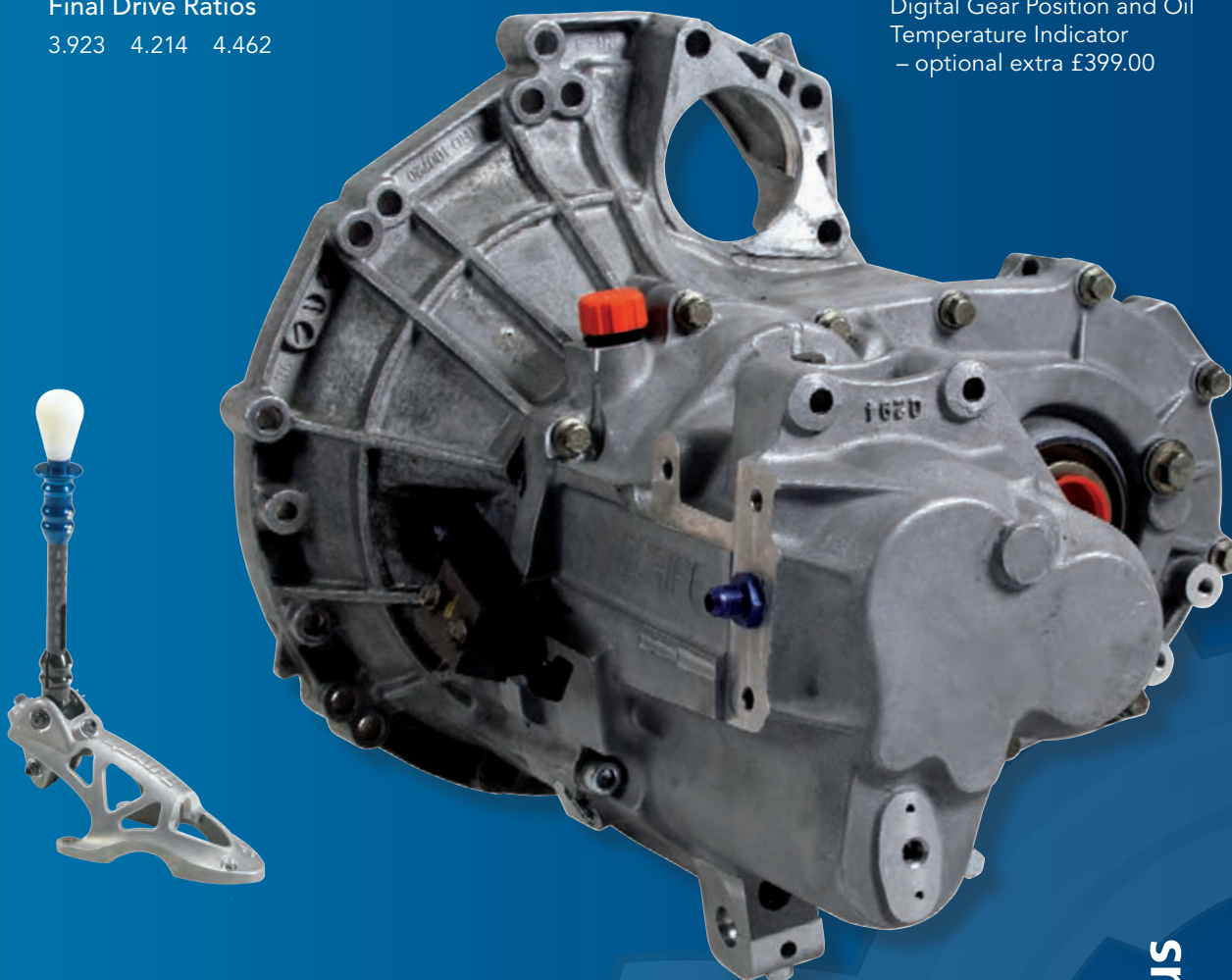

Part no.  
**QKE10R**  
**£4,425.00**

**QDF28K**  
**£575.00**

Additional final drive ratio  
**QRE6R**            **£625.00**

### Order now:

Tel: +44 (0)1732 741144  
 Fax: +44 (0)1732 741555  
 Email: [info@quaife.co.uk](mailto:info@quaife.co.uk)  
 Web: [www.quaife.co.uk](http://www.quaife.co.uk)

PLEASE NOTE: The Quaife QKE10R package includes the new transmission housing, gear lever and cable



# Mitsubishi Lancer Evolution 4-9 Heavy Duty 5-speed Sequential Gearkit



Available exclusively from Quaife agent Momentum Motorsport, QBE6U is a high performance five-speed sequential gear kit incorporating the latest Quaife selection technology to deliver fast and precise gearchanges in a robust, affordable, easy to install package for Mitsubishi Lancer Evolution 4-9 owners.

A direct replacement for the factory 'H'-pattern transmission, the Quaife QBE6U sequential gear kit utilises the original Mitsubishi bell housing, with the addition of a bespoke cast outer case containing a state of the art sequential shift mechanism operated by a new design of Quaife gear lever.

QBE6U's heavy-duty gear train incorporates wider than standard REM ISF® super finished gears that feature the latest open face dog engagement design with larger dog rings and straight cut FIA homologated Group N ratios. Using a gear design already proven in high-powered Mitsubishi Lancer Evolution applications QBE6U offers precise, fast shifts and superior ratios for track day and competition use.

Key technical features of the Quaife QBE6U five-speed Mitsubishi Lancer Evolution sequential gearbox include:-

- Fast and precise Quaife sequential gearchange with replacement lever
- Wider homologated FIA Group N rally gear ratios
- REM ISF® super finished gears
- Quaife final drive ratio included
- Quaife ATB centre differential (QDH11B) available as cost option
- Optional LED digital gear readout available
- Optional paddle shift air cylinder

PLEASE NOTE: The Quaife QBE6U package includes bespoke Quaife outer case and sequential gear lever and is available only as a fully assembled unit



Digital Gear Position and Oil Temperature Indicator  
– optional extra £399.00

## Gear Ratios – Straight cut GpN Rally Set

1st	2nd	3rd	4th	5th
3.000	2.000	1.470	1.111	0.857

## Final Drive Ratios

4.308 4.143



Products available through:  
**Momentum Motorsport**

Tel: +44 (0) 289 262 1822

Email: [info@momentummotorsport.co.uk](mailto:info@momentummotorsport.co.uk)

Web: [www.momentummotorsport.co.uk](http://www.momentummotorsport.co.uk)

Part no.

**QBE6U**

£POA

**QDH11B**

£POA

QBE17Z is a five-speed dog engagement MT75 gearbox for the Ford Escort / Sierra Cosworth 4x4. Technical features include straight-cut, close-ratio gears, a strengthened gearcase plus a heavy duty gear lever and housing. With a 'dog leg' 1st gear and a 1:1 5th gear for Group A use, QBE17Z is a complete gearbox including selectors, interlock, operating block and centre case fitted with standard Ford differential.

Key features of the QBE17Z Ford MT75 dog engagement gearbox for Escort / Sierra Cosworth 4x4 include:-

- Straight-cut, close-ratio dog engagement gears
- Heavy duty gear lever, housing and strengthened gear case
- Uses 'dog leg' 1st gear
- Optional Quaife ATB centre differential
- Also available as QKE17Z MT75 gearkit

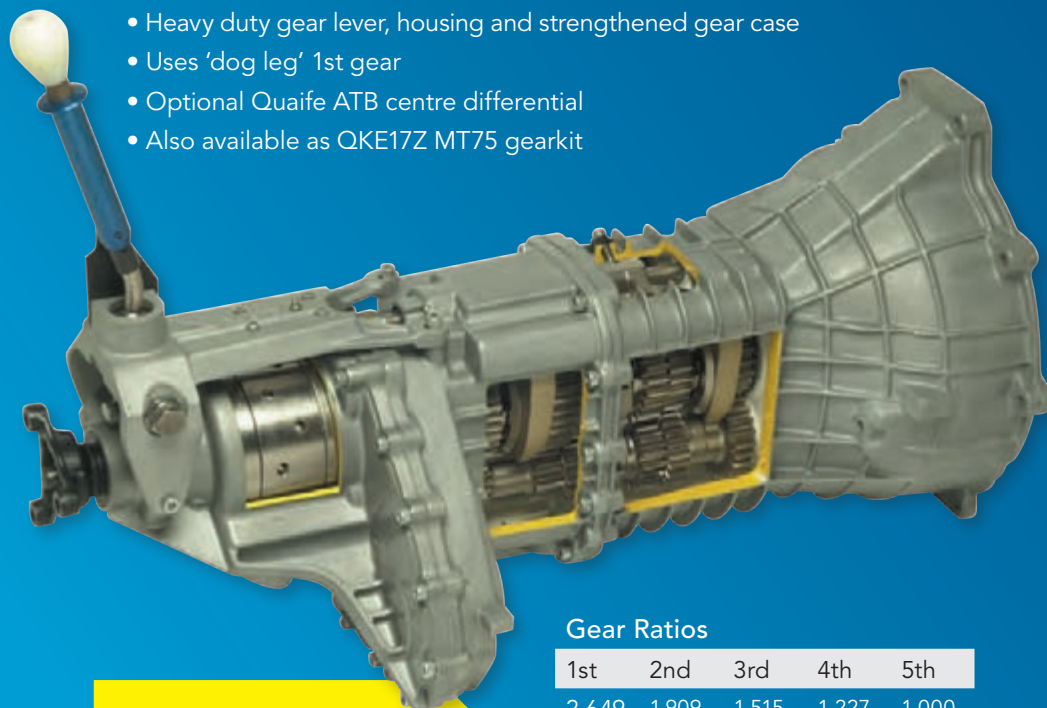

### Gear Ratios

1st	2nd	3rd	4th	5th
2.649	1.909	1.515	1.227	1.000

Part no.

**QBE17Z**

**£8,375.00**

QKE17Z – Gearkit

**£5,650.00**

### Ford MT75 Group N Synchro Gearkit

- Direct replacement for original gearkit
- Helical gears
- Homologated group N ratios
- Specially strengthened gears for improved durability

### Gear Ratios

1st	2nd	3rd	4th	5th	
3.608	2.046	1.373	1.000	0.828	Gp N
3.075	2.063	1.418	1.000	0.825	'Recce'



Part no.

**QKE20Z**

**£3,575.00**

### Order now:

Tel: +44 (0)1732 741144

Fax: +44 (0)1732 741555

Email: [info@quaife.co.uk](mailto:info@quaife.co.uk)

Web: [www.quaife.co.uk](http://www.quaife.co.uk)



QBE9Z is Quaife's heavy duty, H-pattern, dog engagement Ford Rocket (Type E) gearbox, suitable for classic Ford models including the Capri, Cortina, Mk1 / 2 Escort and Sierra. Available only as a complete assembled unit, QBE9Z is designed as an outright competition gearbox, with the latest four dog open face design to ensure ultra-rapid, positive gearshifts.

With durability in mind, QBE9Z features free running gears supported by precision needle roller bearings, which are fitted into a reconditioned crack tested heavy duty Ford gear case (or a modified standard case). A Quaife gear lever and alloy top cover are supplied as standard, while an alloy maincase is a cost option.

Rated to a maximum of 250bhp, QBE9Z features power loss minimising straight-cut, close-ratio gears in a wide choice of motorsport orientated gear ratios.

Key features of the QBE9Z Ford Rocket Heavy Duty Dog Engagement (Type E) gearbox include:

- Straight-cut, close-ratio dog engagement gears for rapid shifts
- Large choice of motorsport gear ratios
- Includes Quaife gear lever and alloy top cover
- Choice of input shaft length for numerous installation options
- Alternative ratios available to order
- See page 46-49 for accessories
- Approximate weight 27Kg (alloy case)

Part no.  
**QBE9Z**

(Iron Maincase)  
**£2,190.00**

(Alloy Maincase)  
**£2,575.00**

**Donor gearbox required**

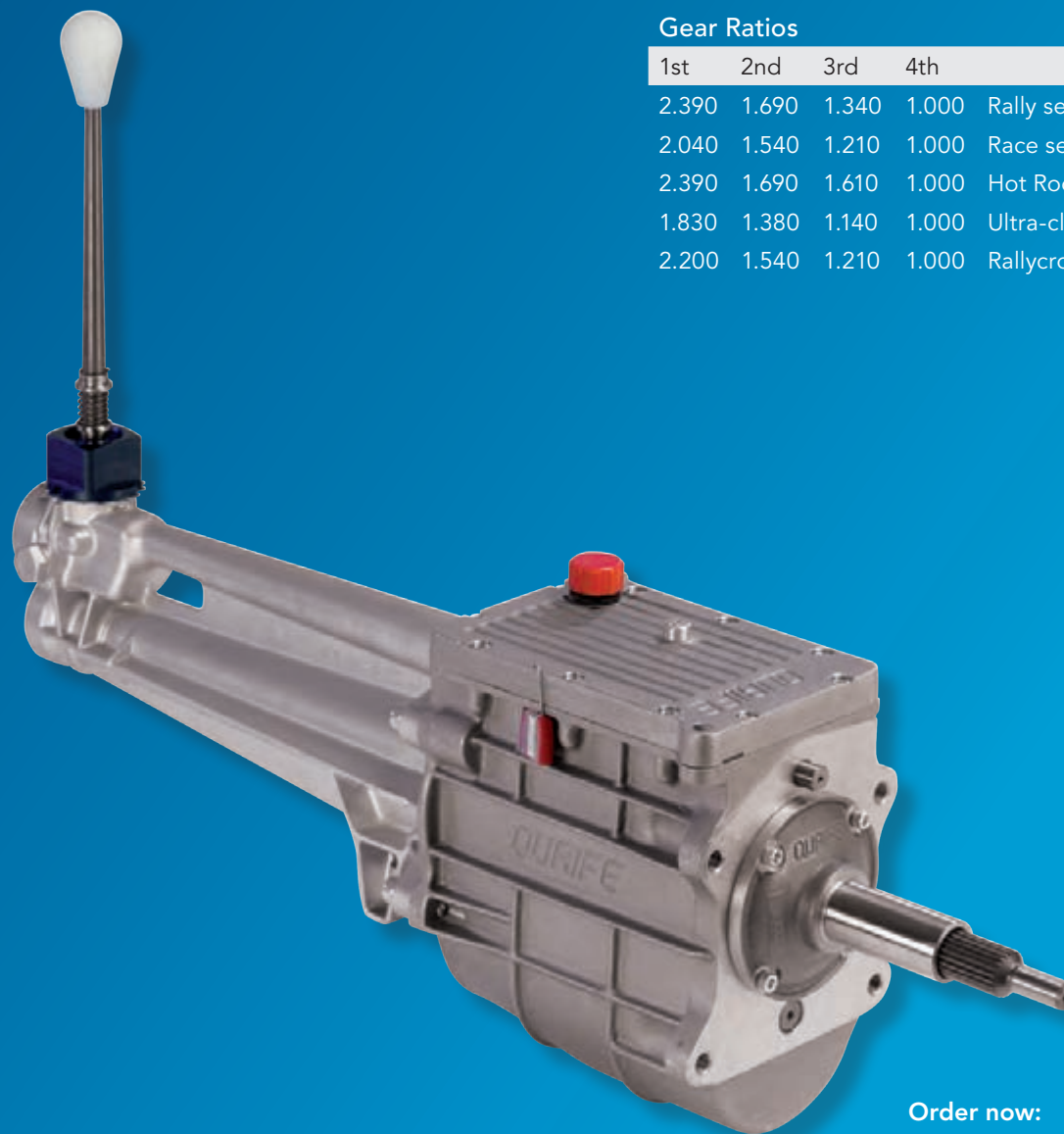

## Gear Ratios

1st	2nd	3rd	4th	
2.390	1.690	1.340	1.000	Rally set
2.040	1.540	1.210	1.000	Race set
2.390	1.690	1.610	1.000	Hot Rod set
1.830	1.380	1.140	1.000	Ultra-close set
2.200	1.540	1.210	1.000	Rallycross set

## Order now:

Tel: +44 (0)1732 741144

Fax: +44 (0)1732 741555

Email: [info@quaife.co.uk](mailto:info@quaife.co.uk)

Web: [www.quaife.co.uk](http://www.quaife.co.uk)



QBE2Z is Quaife's heavy duty, H-pattern, synchromesh Ford Rocket (Type E) gearbox, suitable for classic Ford models including the Capri, Cortina, Mk1/2 Escort and Sierra. The complete assembled unit retains the original synchromesh components and selector mechanisms, while the layshaft is assembled using separate gears.

For optimal reliability, QBE2Z features free running gears supported by precision needle roller bearings, fitted into a reconditioned crack tested heavy duty Ford gear case (or a modified standard case). A Quaife mainshaft and alloy top cover are standard fitment, while an alloy maincase, steel baulk rings, a heavy duty operating block and short tailcase are cost options.

Rated to a maximum of 250bhp, the QBE2Z features power loss minimising straight-cut, close-ratio gears.

Key features of the QBE2Z Ford Rocket heavy duty synchromesh (Type E) gearbox include:

- Straight-cut, close-ratio gears with synchromesh
- Includes Quaife layshaft spindle and alloy top cover
- Choice of input shaft length for numerous installation options
- For all optional extras, please see page 46-49 (gearlever not included)
- Alternative ratios available to order

### QBE2Z Gear Ratios

1st	2nd	3rd	4th	
2.390	1.690	1.340	1.000	Rally set
2.040	1.540	1.210	1.000	Race set
2.390	1.690	1.610	1.000	Hot Rod set
1.830	1.380	1.140	1.000	Ultra-close set
2.200	1.540	1.210	1.000	Rallycross set



The QBE6Z is a 4-speed Clubman synchromesh Ford Rocket (Type E) gearbox, suitable for classic Ford models including the Capri, Cortina, Mk1/2 Escort and Sierra. The complete assembled gearbox is designed as a motorsport orientated gearbox, which retains the original Ford mainshaft, synchromesh components and selector mechanisms, while the layshaft is assembled using separate gears.

Rated to a maximum of 190bhp, QBE6Z features power loss minimising straight-cut, close-ratio gears fitted into a reconditioned crack tested heavy duty Ford gear case (or a modified standard case).

An alloy maincase, alloy top cover, steel baulk rings, Quaife gear lever and a heavy duty operating block are available cost options.

Key features of the QBE6Z Ford Rocket (Type E) Clubman synchromesh gearbox include:

- Straight-cut, close-ratio gears with synchromesh engagement
- Large choice of motorsport gear ratios
- Choice of input shaft length for numerous installation options
- Alternative ratios available to order

### QBE6Z Gear Ratios

1st	2nd	3rd	4th	
2.480	1.690	1.210	1.000	Rally / Race set
2.480	1.690	1.610	1.000	Hot Rod set
2.290	2.070	1.950	1.000	BRISCA F2
3.030	2.070	1.950	1.000	Spedeworth

PLEASE NOTE: Quaife 4-Speed straight-cut synchromesh gearkits (see page 62) are also available, as well as various short tailcase options (see page 46).

Part no.  
**QBE2Z**

(Iron Maincase)  
**£1,475.00**

(Alloy Maincase)  
**£1,900.00**

**Donor box required**

### Order now:

Tel: +44 (0)1732 741144

Fax: +44 (0)1732 741555

Email: [info@quaife.co.uk](mailto:info@quaife.co.uk)

Web: [www.quaife.co.uk](http://www.quaife.co.uk)

Part no.  
**QBE6Z**

(Iron Maincase)  
**£1,025.00**

(Alloy Maincase)  
**£1,475.00**

**Donor box required**

The QBE22Z is Quaife Engineering's 5-speed dog engagement Ford Sierra Type 9 gearbox, suitable for classic Ford models including the Escort Mk1/2 and Sierra. Available only as a complete assembled unit, QBE22Z is designed as an outright competition gearbox, with the latest four dog open face design to ensure ultra-rapid, positive gearshifts, while the layshaft is assembled using separate gears.

To ensure reliability, the QBE22Z features free running gears supported by precision needle roller bearings. An alloy maincase, alloy top cover and Quaife gear lever are supplied as standard fitment.

Rated to a maximum of 250bhp, QBE22Z features power loss minimising straight-cut, close-ratio gears in a wide choice of motorsport orientated gear ratios.

Key features of the QBE22Z Ford Sierra Type 9 5-speed dog engagement gearbox include:

- Straight-cut, close-ratio dog engagement gears for rapid shifts
- Large choice of motorsport gear ratios
- Includes Quaife gear lever, alloy top cover and maincase
- Choice of input shaft length for numerous installation options
- Alternative ratios available to order

## Gear Ratios

1st	2nd	3rd	4th	5th
2.390	1.690	1.340	1.000	0.930
2.200	1.540	1.210		0.870
2.040	1.380	1.140		
1.830				

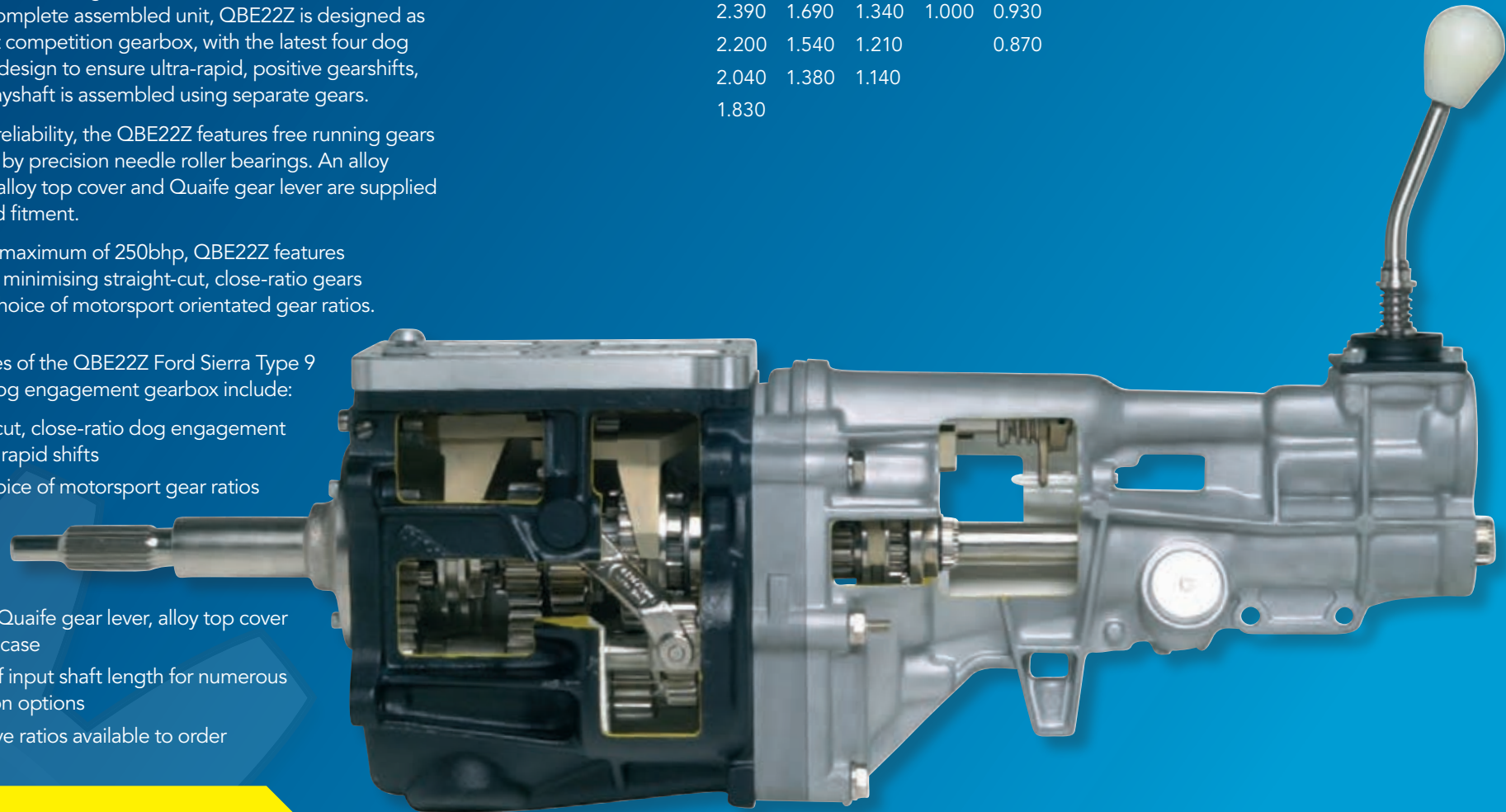

Part no.

**QBE22Z**

**£3,525.00**

**Donor box required**

## Order now:

Tel: +44 (0)1732 741144

Fax: +44 (0)1732 741555

Email: [info@quaife.co.uk](mailto:info@quaife.co.uk)

Web: [www.quaife.co.uk](http://www.quaife.co.uk)



QBE15Z is Quaife's heavy duty, H-pattern, synchromesh engagement Ford Sierra (Type 9) gearbox, suitable for classic Ford models including the Capri, Cortina, Mk1/2 Escort and Sierra. This competition orientated gearbox, retains the original synchromesh components and selector mechanisms, while the layshaft is assembled using separate gears.

QBE15Z features free running gears supported by precision needle roller bearings on a Quaife produced mainshaft, fitted into a modified reconditioned crack tested Ford gear case. A Quaife alloy maincase, steel baulk rings, and a heavy duty operating block are cost options.

Rated to a maximum of 250bhp, the QBE15Z features power loss minimising straight-cut, close-ratio gears.

Key features of the QBE15Z Ford Sierra (Type 9) heavy duty synchromesh engagement gearbox include:

- Straight-cut, close-ratio gears with synchromesh
- Large choice of motorsport gear ratios
- Optional big tooth helical gears
- Choice of input shaft length for numerous installation options
- For all optional extras, please see page 46-49

### QBE15Z Gear Ratios

1st	2nd	3rd	4th	5th
2.390	1.690	1.210	1.000	0.930
2.200	1.540			0.870
2.040				

### QBE13Z Gear Ratios

1st	2nd	3rd	4th	5th
2.745	1.690	1.210	1.000	0.930
2.390	1.540			0.870
2.200				
2.040				

The QBE13Z is a 5-speed Clubman synchromesh Ford Sierra (Type 9) gearbox, suitable for classic Ford models including the Escort Mk1/2 and Sierra. As a complete assembled gearbox QBE13Z retains the original Ford mainshaft, synchromesh components and selector mechanisms, while the layshaft is assembled using separate gears.

Rated to a maximum of 190bhp, QBE13Z features power loss minimising straight-cut, close-ratio gears in a wide choice of motorsport orientated gear ratios, fitted into a reconditioned crack tested Ford gear case.

An alloy maincase, alloy top cover, steel baulk rings, Quaife gear lever and a heavy duty operating block are available cost options.

Key features of the QBE13Z Ford Sierra Type 9 Clubman synchromesh gearbox include:

- Straight-cut, close-ratio gears with synchromesh engagement
- Large choice of motorsport gear ratios
- Choice of input shaft length for numerous installation options
- Alternative ratios available to order
- For all optional extras, please see page 46-49

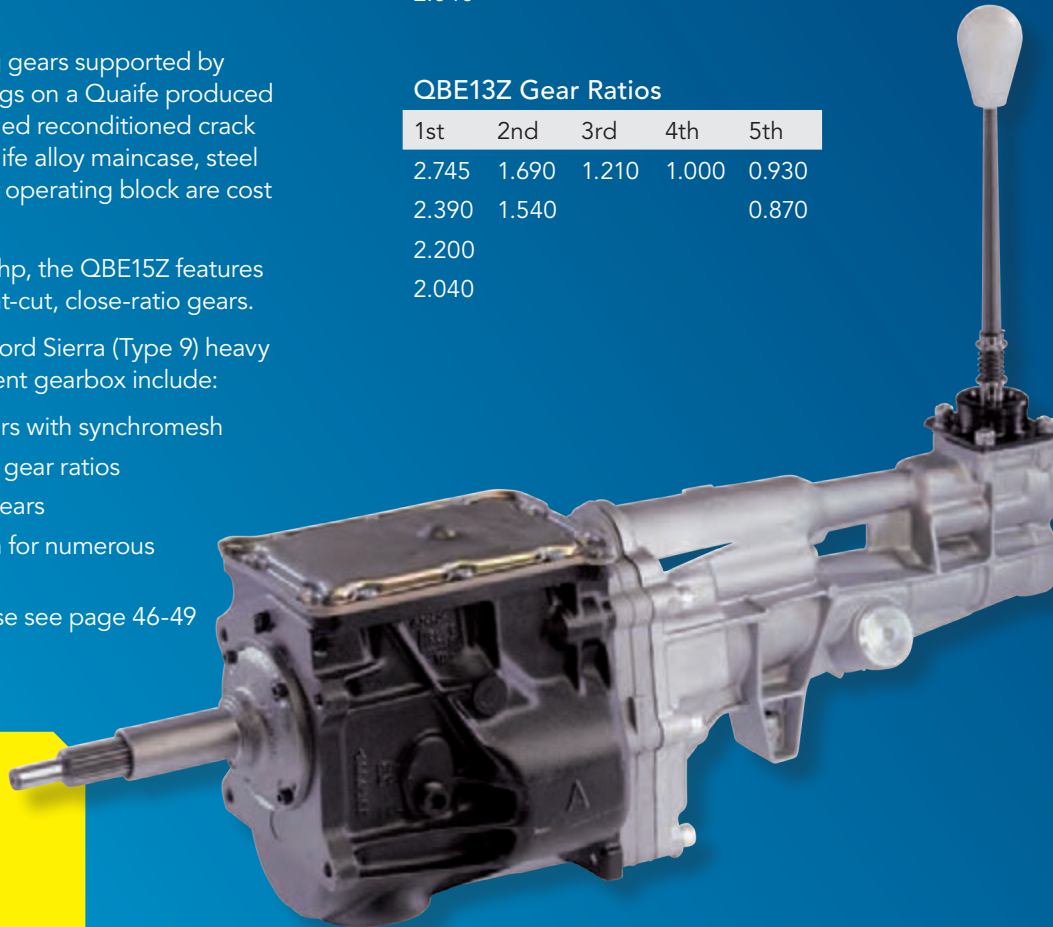

Part no.  
**QBE15Z**

(Iron Maincase)  
**£1,925.00**

(Alloy Maincase)  
**£2,575.00**

**Donor box required**

### Order now:

Tel: +44 (0)1732 741144

Fax: +44 (0)1732 741555

Email: [info@quaife.co.uk](mailto:info@quaife.co.uk)

Web: [www.quaife.co.uk](http://www.quaife.co.uk)

PLEASE NOTE: Quaife 5-Speed straight-cut synchromesh gearkits are also available, as are semi-helical versions (see page 63).

Part no.  
**QBE13Z**

(Iron Maincase)  
**£1,335.00**

(Alloy Maincase)  
**£1,985.00**

**Donor box required**



### Ford Rocket Short Tailcase

- Available for heavy duty and dog Rocket gearboxes
- **NEW: Clubman version now available for oval applications**
- **NEW: Suits Sierra gear lever**
- Moves gear lever and prop shaft 10" forward
- Gives improved universal joint angles
- Ideal for Clubman type sports cars
- Rocket or Bullet output spline available



### Short tailcase conversion kit to fit:

Customer's Quaife gearbox (synchro)

**QKSTC001** £540.00

Customer's Quaife gearbox (dog)

**QKSTC002** £540.00

Clubman or Standard gearbox

**QKSTC005** £POA

### Ford Rocket and Sierra Gear Levers

- Short lever throw for quicker gear change
- Spherical bearing ensures smooth, positive action
- Hardened, one piece lever for extra strength
- Long or short versions available
- Nylon gear knob available for Quaife or standard levers

### Ford Rocket 4-speed gear lever, straight 12" with 10mm thread

**QGE2Z001** £87.50

### Ford Rocket 4-speed gear lever, bent 8" with 12mm thread

**QGE2Z002** £87.50

### Ford Rocket 4-speed gear lever, straight 12" with 10mm thread (3 bolt tailcase)

**QGE2Z003** £87.50

### Ford Sierra 5-speed gear lever, straight 12" with 10mm thread

**QGE11Z001** £87.50

### Ford Sierra 5-speed gear lever, bent 8" with 12mm thread

**QGE11Z002** £87.50

### Ford Sierra 5-speed Caterham gear lever 3/8" UNC thread

**QGE11Z003** £87.50

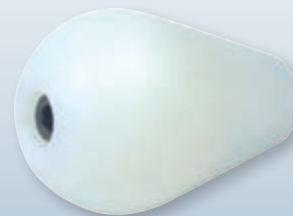

### Ford Rocket and Sierra Gear Knobs

Nylon gear knob (10mm thread)

**QGE11Z004** £17.50

Nylon gear knob (12mm x 1.75 thread)

**QGE11Z005** £17.50

Nylon gear knob (12mm x 1.50 thread)

**QGE11Z006** £17.50

Nylon gear knob (3/8" UNC thread)

**QGE11Z007** £17.50



### Quaife Alloy Maincases:

- Produced using LM25
- **NEW: Aerospace grade L169 available as a cost option**
- Rocket alloy maincase saves approximately 3.7 kg
- Sierra alloy maincase saves approximately 4.5 kg

Ford Rocket (Type E) Clubman

**QMAMCCL** £435.00

Ford Rocket (Type E) Heavy Duty

**QMAMC4** £435.00

Ford Sierra (Type 9) Heavy Duty

**QMAMC5** £435.00

Layshaft spindle (required with 5-speed alloy maincase if not used with Ford stub)

**E14Z1-39** £60.00

### Quaife Alloy Top Covers:

- Produced using LM25
- Alloy top covers greatly increase the rigidity of the maincase
- Includes all bolts, dowels and breather

Ford Rocket (Type E)

**QMATC4** £65.00

Ford Sierra (Type 9)

**QMATC5** £80.00

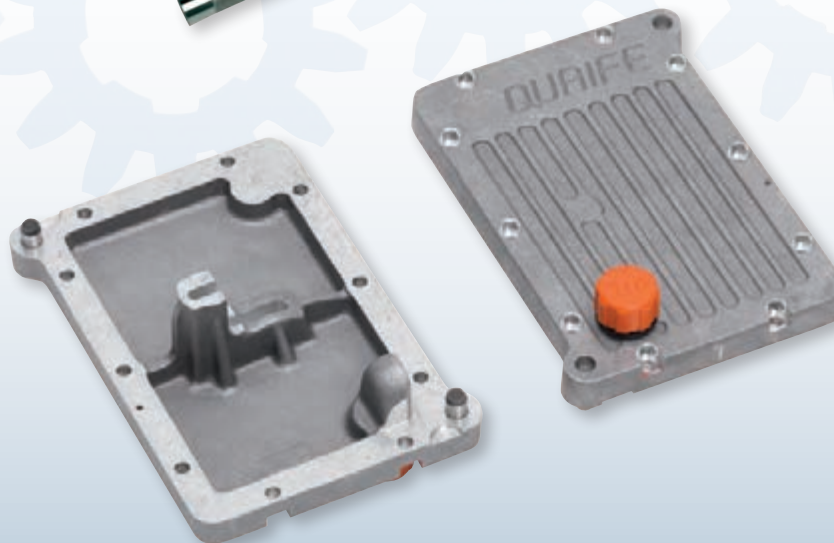
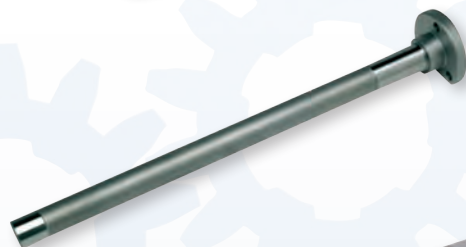
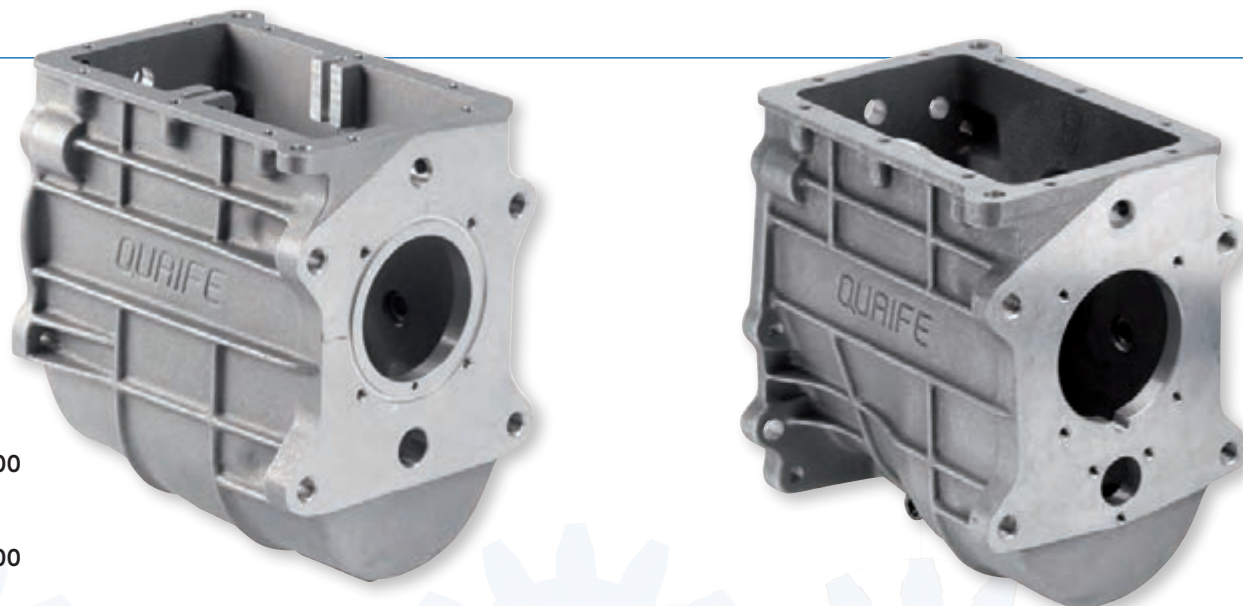

### Quaife Alloy Nose Cones:

- Produced using LM25
- Fitted with steel over tube for clutch release bearing

Ford Rocket (Type E)

**E2Z1119 Long – V6** £58.50

**E2Z1135 Short – 4cyl** £58.50

**E2Z1129 Cast iron** £50.00

Ford Sierra (Type 9)

**E15Z123 Long – V6** £58.50

**E15Z126 Short – 4cyl** £58.50



**Ford Rocket / Sierra Steel Baulk Rings:**

Ford Rocket/Sierra steel baulk rings 1st-2nd

**E13Z1-25** £85.00

Ford Sierra steel baulk rings 3rd-4th

**E13Z1-26** £85.00

Ford Rocket steel baulk rings 3rd-4th

**E2Z1-89** £85.00

Ford Bullet steel baulk rings 1st-2nd

**E3Z1-21** £POA

Ford Bullet steel baulk rings 3rd-4th

**E3Z1-22** £POA**ZF Components (S5/18 transmission) & Side Gears:**

ZF input pair

**QMD1V001** £460.00

ZF gear lever

**D1A1-139** £180.00

ZF side gears (each)

**F1A1-60** £87.50**Pinto Camshaft Pulley**

- Peg vernier adjustment
- Ensures accurate valve timing
- Steel or alloy versions

Pinto camshaft pulley – alloy

**QEPPA** £62.50

Pinto camshaft pulley – steel

**QEPPS** £52.50**Cosworth Camshaft Pulley**

- Peg vernier adjustment
- Ensures accurate valve timing
- Steel or alloy versions

Cosworth YB camshaft pulley – alloy

**QEPCA** £62.50

Cosworth YB camshaft pulley – steel

**QEPCS** £52.50**Heavy Duty Operating Block**

- Fits Rocket and Sierra gearboxes
- Made in one piece from steel billet
- Direct replacement – no modifications required

**E2Z1-69**

£81.00



### Sierra Group A Type Upright

- Stronger and lighter than original parts
- Made from heat treated LM25 alloy or magnesium

MacPherson strut-type uprights

**D1A1-671 £460.00**

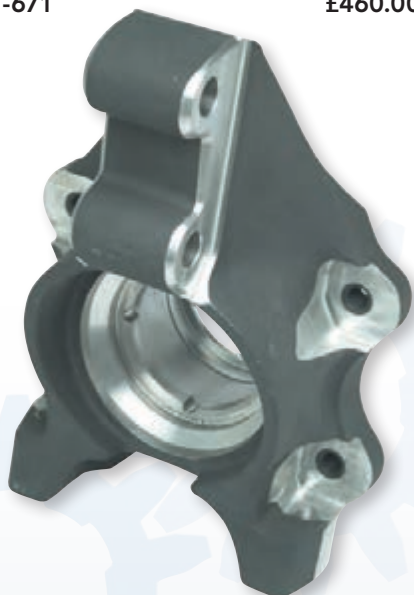

### Ford Escort / Sierra 6½" 4x4 Heavy Duty Front Differential Case

**F18Z1-02 £795.00**

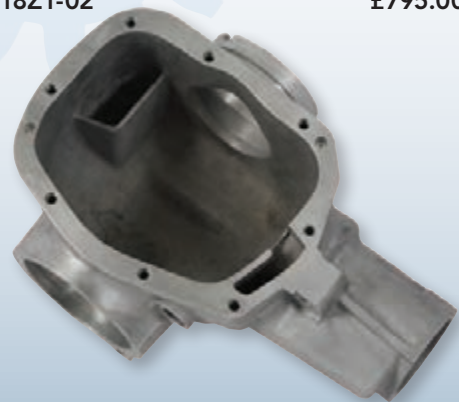

### Reconditioned Complete Sierra 7" ATB Differential Assembly

Ford Sierra 7" Quaife ATB diff assembly (uses reconditioned cases)

**QAF15Z £1,210.00**

Ford Sierra 7" Quaife ATB diff assembly with flanges (uses reconditioned cases)

**QAF15ZFL £1,415.00**

### Reconditioned Complete Sierra 7" Tran-X LSD Assembly

Ford Sierra 7" Tran-X LSD diff assembly (uses reconditioned cases)

**QAF15Z £1,210.00**

Ford Sierra 7" Tran-X LSD diff assembly with flanges (uses reconditioned cases)

**QAF15ZFL £1,415.00**



### Reconditioned Ford Sierra (Type 9) Synchromesh Gearbox

- Complete units using all new bearings, seals and gaskets
- Various input shaft lengths and gear ratios available

**QBE37Z £POA**

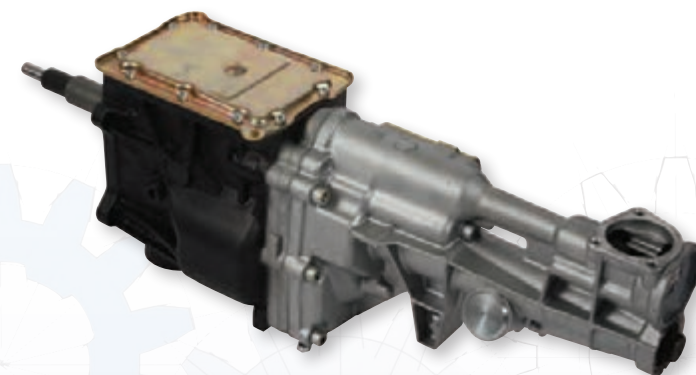

### Sierra 7" CWP Options

- R3.14:1 & R3.38:1 available as used Ford only
- R3.62:1 & R3.92:1 available as used Ford or new Manganese Phosphate coated
- R4.11:1, R4.44:1 & R4.71:1 available as new Manganese Phosphate coated
- For details see page 97



### Quaife/RPE Gear Drive System

QBA3R is designed to provide a compact, unified gear based drive system for motorcycle engine cars and as such, is suitable for use with the majority of popular Japanese superbike powerplants. Developed jointly by Quaife and RPE, QBA3R is used as original equipment fitment on the award-winning Radical SR3 sportscar.

Directly driven from a motorcycle engine's gearbox output shaft, power is transmitted through QBA3R via a unique shock absorbing cushion drive coupling and then passes through a pair of user changeable reduction gears to a Escort/Fiesta Quaife ATB helical gear limited slip differential. QBA3R features an integral, cable operated reverse system and uses easily available joints and shafts, or driveshafts can be manufactured to customer's specification on request.

Key technical features of the Quaife/RPE QBA3R gear drive system include:-

- Direct drive from motorcycle engine gearbox output
- User changeable reduction gears with ratios from 2.9:1 to 3.6:1
- Cable push-pull operated reverse system
- Uses Quaife Escort/Fiesta ATB helical gear limited slip differential
- Uses easily available joints and shafts or
- Drive shafts made to suit your application
- Final drive ratio 2.5:1
- Weight approximately 25kg
- Over 1,000 in use worldwide

Part no.  
**QBA3R**  
**£POA**

#### Order now:

Tel: +44 (0)1732 741144  
Fax: +44 (0)1732 741555  
Email: [info@quaife.co.uk](mailto:info@quaife.co.uk)  
Web: [www.quaife.co.uk](http://www.quaife.co.uk)



### Quaife/RPE Reversing Differential

QBA7R is a compact, chain driven automatic torque biasing differential unit which features an integral reversing mechanism. Developed jointly by Quaife and Radical Performance Engines, QBA7R is used as original equipment fitment on the award-winning Radical SR4 sportscar.

The QBA7R features an integrated Quaife ATB helical gear limited slip differential and a cable push-pull operated selector fork engagement. Synchromesh engagement features on reverse, combined with a dog engagement on the forward drive, while a positive index lock is incorporated into the differential bearing support.

Key technical features of the Quaife/RPE QBA7R reversing differential include:-

- Synchromesh engagement on reverse gear
- Integrated Quaife ATB helical gear limited slip differential
- Cable push-pull operated selector fork arrangement

Part no.  
**QBA7R**  
**£POA**



## Quaife Universal Chain Drive Axle Unit

QBA2R is a combined differential, reverse and reduction box assembly designed for motorcycle engined vehicles. QBA2R can be installed horizontally (for racing and sportscar use) or vertically for use in off-road buggies and karts where ground clearance is a critical issue.

QBA2R incorporates a Quaife Escort/Fiesta ATB helical gear limited slip differential, ensuring compatibility with readily available driveshafts and joints. Alternatively, Quaife can manufacture driveshafts and flanges to customer specifications. An optional 100mm or 108mm Lobro joint compatible drive flange is also available.

Key technical features of the QBA2R Quaife reversing differential unit include:-

- Capable of either horizontal or vertical mounting in vehicles
- Includes integrated Escort/Fiesta Quaife ATB differential
- Features internal reduction ratios from 2.430:1 to 3.767:1
- Reverse gear ratio 2.92:1
- Drive flange replaces standard drive shaft joint
- Used with taper lock sprocket or splined input shaft
- Recommended oil: 75W90 GL5 (see page 107)
- Weight 22kg
- Over 500 in use worldwide

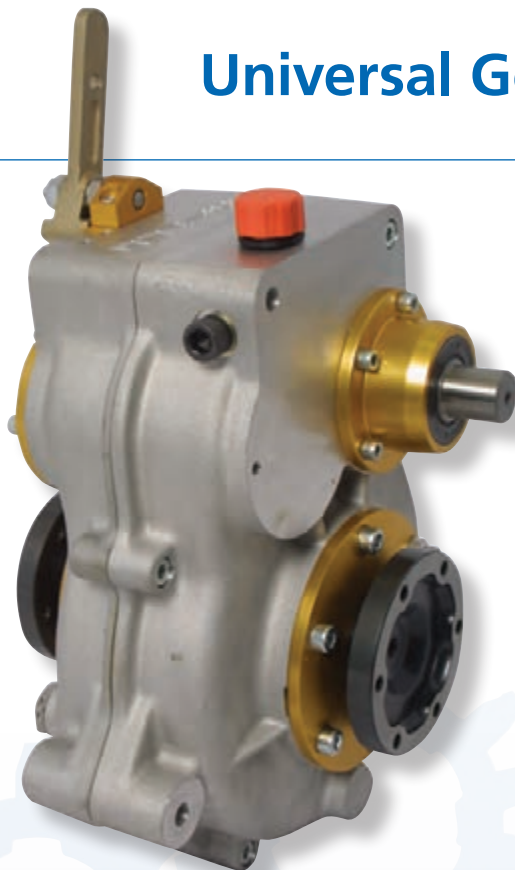

## Quaife QBA11R Universal Gear Drive Transfer Unit

QBA11R is designed to enable the easy connection of QBA2R Quaife CD axle unit to the majority of motorcycle engine gearbox output shafts. Quaife can manufacture adaptor plates to customer specifications to optimise the positioning of the Quaife QBA2R CD axle unit to suit individual requirements. QBA11R is a sealed unit to allow for ease of installation and features a cushion drive on the input and a quiet, strong, helical gear drivetrain.

Key technical features of the Quaife QBA11R universal gear driven unit include:-

- Sealed unit for easy installation
- Helical gear drive and input includes cushion drive
- Transfer ratio 1.0:1 or 1.250:1
- Overall ratio from 2.430:1 to 4.709:1

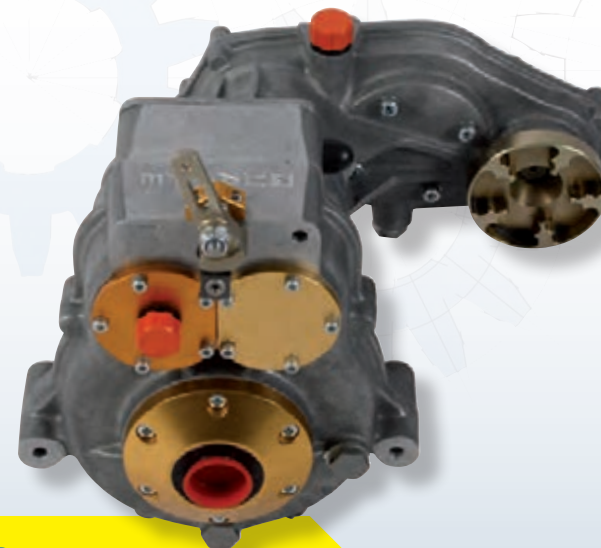

Part no.

**QBA2R**

**£1,880.00**

Optional lobro joint

**F7Z432 £160.00**

(2 x Required)

Order now:

Tel: +44 (0)1732 741144

Fax: +44 (0)1732 741555

Email: info@quaife.co.uk

Web: www.quaife.co.uk

Part no.

**QBA11R**

**£3,220.00**

Optional lobro joint

**F7Z432 £160.00**

(2 x Required)



### Universal Axle Unit

QBA4R is an all-in-one transmission solution for motorcycle engined vehicles, which packages a reverse gear system and Quaife ATB differential in a purpose designed, compact, reliable unit.

QBA4R uses 195mm centres, with an input shaft that can be designed to suit a wide variety of applications, while a choice of straight-cut or helical gears make QBA4R ideal for both race and corporate events where noise management is an issue.

Key technical features of QBA4R include:-

- A range of internal reduction ratios from 5.869:1 to 8.100:1
- Quaife Escort/Fiesta ATB differential included
- Uses readily available joints and driveshafts
- Custom shafts also available to order
- For use with CVT clutch, chain drive or electric motor
- Optional lock-out mechanism for differential

Part no.

**QBA4R (reverse)**

From **£2,130.00**

**QBA5R (no reverse)**

From **£1,720.00**

Optional lobro joint

**F7Z432 £160.00**

(2 x Required)

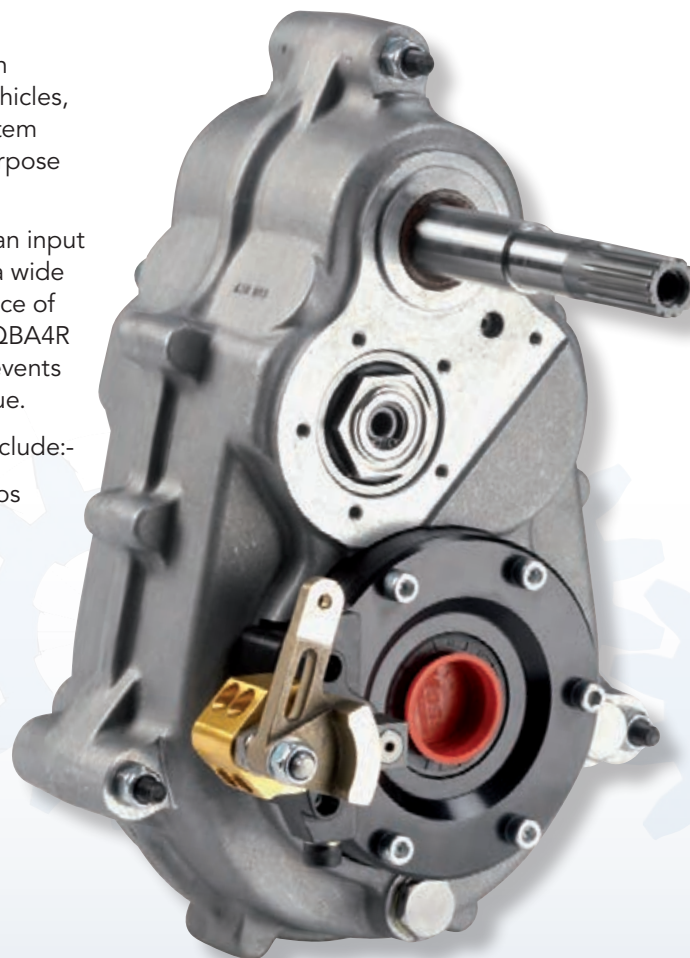

### ATB Differential for Chain Driven Vehicles

QDF7ZR is Quaife's original, Ford Fiesta based grease filled ATB differential, which has been designed to offer a chain driven traction solution where economy and lightweight are primary considerations. QDF7ZR is a sealed unit which simply requires greasing periodically to ensure perfect operation.

Key technical features of the QDF7ZR chain driven ATB differential include:-

- Ground spigot to minimise sprocket run out
- Uses Escort/Fiesta outputs
- Sprocket not included (available from [www.fptgroup.com](http://www.fptgroup.com))
- Lubricate with LM grease



Part no.

**QDF7ZR**

**£575.00**

Optional lobro joint

**F7Z432 £160.00**

(2 x Required)

### Order now:

Tel: +44 (0)1732 741144

Fax: +44 (0)1732 741555

Email: [info@quaife.co.uk](mailto:info@quaife.co.uk)

Web: [www.quaife.co.uk](http://www.quaife.co.uk)

## In-line Reversing Box

QBE35G was developed by Quaife to provide a reverse gear solution for motorcycle engined cars running an in-line powertrain installation.

To avoid unnecessary power loss, QBE35G has been designed to be a 'straight-through' type when running in 'forward' mode, therefore absorbing less power than conventional designs. A compact, heavy duty unit, QBE35G features billet aluminium cases and uses readily available Ford English axle flanges.

Operated by a cable or other remote device via a short lever or optional longer lever, a Quaife breather bottle is also available as an option for QBE35G.

Key technical features of the QBE35G Quaife reversing differential unit include:-

- Designed for in-line use only
- Straight through design in forward mode to minimise power loss
- Uses billet aluminium cases
- Operated by short lever or optional longer lever (shown right)
- Weight only 8kg
- Over 1000 in use worldwide



### Options

Quaife breather bottle	<b>QMBBA</b>	<b>£40.00</b>
Short lever	<b>QBE35G001</b>	<b>£775.00</b>
Long lever (pictured)	<b>QBE35G002</b>	<b>£775.00</b>

### Order now:

Tel: +44 (0)1732 741144

Fax: +44 (0)1732 741555

Email: [info@quaife.co.uk](mailto:info@quaife.co.uk)

Web: [www.quaife.co.uk](http://www.quaife.co.uk)

Part no.  
**QBE35G**  
**£775.00**

### QBD3M Twin-Motor Upright Winch (GP8 Winch Series)

These winches are the pinnacle of excellence. With 36 ratio and motor options available there is a winch for every application

- Twin motors for twice the power
- High mount compact design
- Pneumatic freespool for easy no fuss operation
- Heavy duty LM25 heated treated casings
- 12 mounting points
- High-strength external billet brake
- Suitable for use with synthetic winch lines
- Large bearings give efficient and smooth operation
- Filler and magnetic drain plugs as standard
- Large heavy duty drum available in different sizes
- GP designed rope retention system
- Raised breather to allow submersion
- Rear brace bars to support the winch
- EN36 case hardened geartrain giving strength and reliability

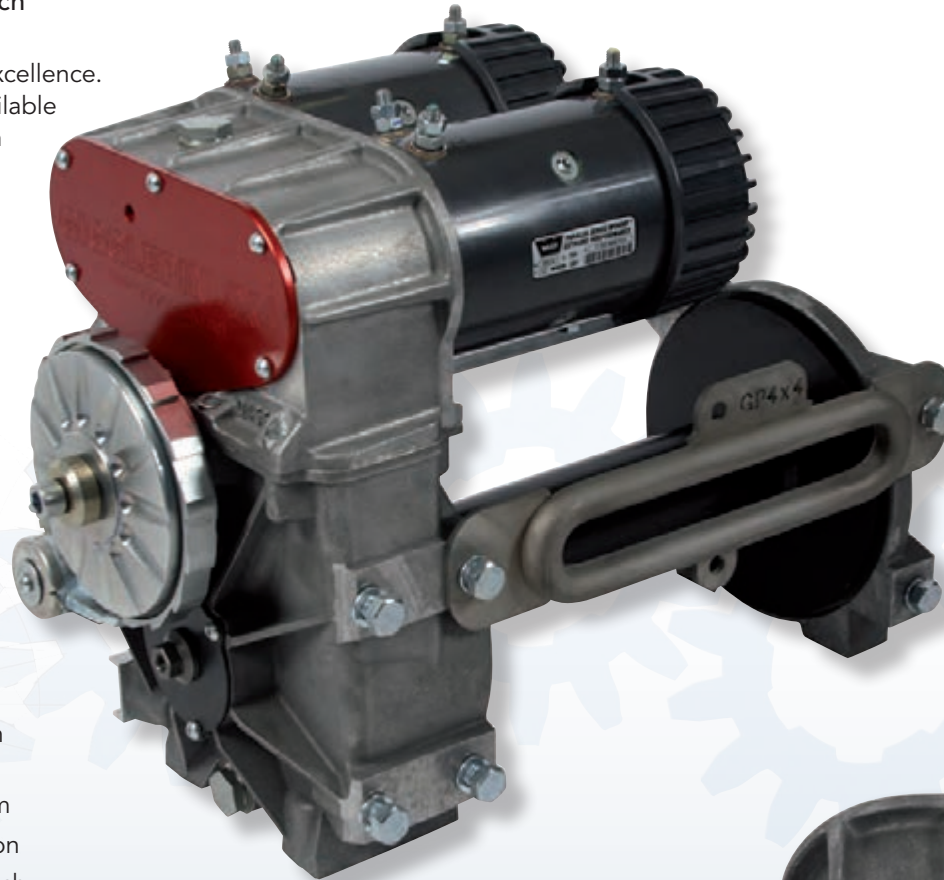

### Twin-Motor top housing for WARN 8274 winch

This system has been developed to maximise the Warn 8274 potential. Using the excellent 6HP Warn XP motors for 12v applications, or the rugged Bowmotor for 24v applications, this system gives you the power, strength and reliability you need.

In short the Advantages of the Twin Motor Top Housing are:

- Twice the power, twice the speed
- Decreased motor effort, saving motors and batteries
- Superior design and material grades eliminating breakage
- Sustained line rate on hard pulls
- Higher maximum load capacity

Also available:

- Up-rated Warn 8274 mainshaft kit for use with or without Twin-Motor top housing
- Various ratio options for Twin-Motor top housing for different applications



Products available through:

**Gigglepin 4x4**

Tel: +44 (0) 1732 463600

Email: [shop@gigglepin4x4.net](mailto:shop@gigglepin4x4.net)

Web: [www.gigglepin4x4.net](http://www.gigglepin4x4.net)



## QBD5M Twin-Motor Low-line Winch (GP9 Winch Series)

With its compact height this winch lends itself to being fitted to load beds and trucks where space is at a premium.

- Compact lowline winch
- Twin motors for twice the power
- Pneumatic freespool for easy no fuss operation
- Heavy duty LM25 heated treated casings
- High-strength external billet brake
- Suitable for use with synthetic winch lines
- Large bearings give efficient and smooth operation
- Filler and magnetic drain plugs as standard
- Large heavy duty drum with rope retention system
- Raised breather to allow submersion
- Rear brace bars to support the winch
- EN36 case hardened geartrain giving strength and reliability
- Multiple speed and motor options available
- 11 mounting points



## QBD6M Twin Motor Worm-Drive Winch (GP10 Winch Series)

This Twinmotor winch uses a worm drive to give perfect loading in either direction, with its low height and huge power it is a great alternative when space is limited.

- Heavy-duty worm drive gears for high torque loading
- Twin motors for twice the power
- Pneumatic freespool for easy, no fuss operation
- Heavy duty LM65 heated treated casings
- High-strength external billet brake
- Large bearings give efficient and smooth operation
- Filler and magnetic drain plugs as standard
- Large heavy duty drum with rope retention system
- Raised breather to allow submersion
- Multiple speed and motor options available
- Easy access to gear train for service, replacement and ratio change

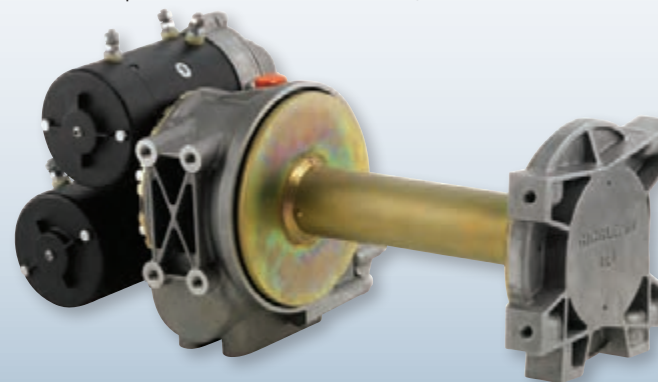

## QBD11M Giggiepin Twin-Speed

**New for 2015:** designed and manufactured by Quaife for Giggiepin 4x4, the very latest in competition winches where only the fastest, strongest, safest and most reliable winch will do.

- Two motors for torque and power
- Two speeds for ultimate control
- Two types of brake for safety and ease of use
- Mountable on multiple planes
- Raised breather to allow submersion
- GP designed rope retention system
- Suitable for use with synthetic winch lines
- Rear brace bars to support the winch



Quaife designs and produces a number of specialist drivetrain components for the historic Lotus Elan.

## Lotus Elan (Ford Bullet) Lightweight Alloy Components

Produced from brand new, lightweight castings using state of the art CNC machinery, Quaife's range of light alloy Lotus Elan transmission components includes:-

Bellhousing – Alloy	£POA
Bellhousing – Magnesium	£POA
Maincase – Magnesium	£POA
Tailcase – Alloy	£POA
English diff nose – Alloy	£POA
Front / Rear uprights – Alloy	£POA
Front / Rear uprights – Magnesium	£POA
Front / Rear hubs – Alloy	£POA

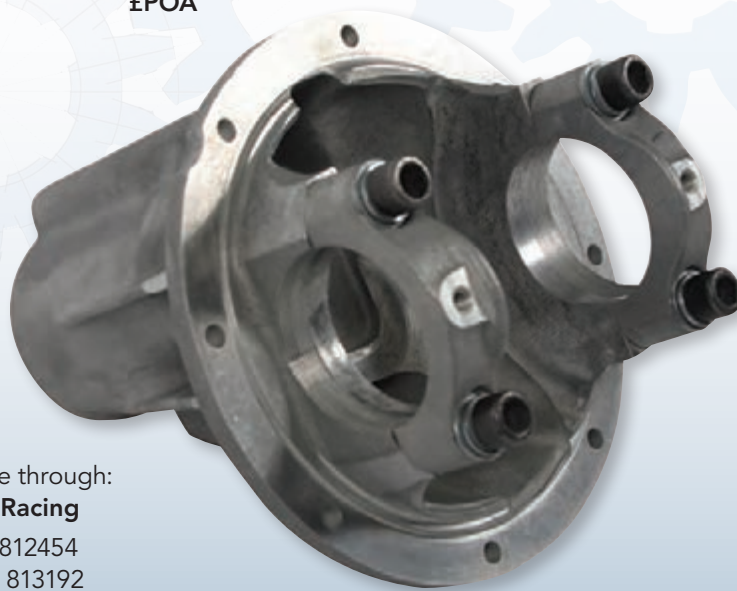

## Elan Drive Flanges

Quaife manufactures a range of drive flanges specifically designed for the Lotus Elan. Produced using modern CNC machinery to tight tolerances, key features include:-

- Manufactured from high quality uprated steel
- Various sizes and spline designs available



### Norton 5-Speed Gearkit

- Road or race versions available
- Choice of mainshaft – 7R / G50, Manx, Dominator, Commando
- Normal or reverse cam plate
- Optional heavy duty alloy or magnesium maincase



#### Gear Ratios

1st	2nd	3rd	4th	5th	
1.986	1.654	1.351	1.106	1.000	Race
2.118					Race / Road
2.357					Road

Part no.  
**QMCA1H**  
**£POA**

Products available through:  
**Mick Hemmings Motorcycles**  
Tel: +44 (0) 1604 638505  
Fax: +44 (0) 1604 631838

### Norton Heavy Duty Maincase

- Strengthened aluminium or magnesium castings
- Bushed and ready to fit
- Direct replacement for original



Alloy maincase

**A1H100A**

**£POA**

Magnesium maincase

**A1H100M**

**£POA**

### Norton 6-Speed Gearkit

- Choice of mainshaft – 7R / G50, Manx, Dominator, Commando
- Standard or Reverse camdrum
- Includes ultra-lightweight magnesium cases



#### Gear Ratios

1st	2nd	3rd	4th	5th	6th
2.250	1.737	1.429	1.227	1.109	1.000

Part no.  
**QMCA6H**  
**£POA**



### Triumph Bonneville /

#### Trident Triple 5-Speed Gearkit

- Available for 650 / 750 twin and 750 triple

#### Gear Ratios

1st	2nd	3rd	4th	5th
2.200	1.750	1.400	1.250	1.000
1.960	1.560	1.250	1.120	1.000

### Triumph 500 Twin 5-Speed Gearkit

#### Gear Ratios

1st	2nd	3rd	4th	5th	
1.960	1.560	1.250	1.120	1.000	Race
2.210					
2.550	1.660	1.330	1.120	1.000	Road

### Triumph T150 6-Speed Conversion Gearkit

- 5 to 6 speed conversion gearkit
- Replacement inner cover
- Close ratio
- New 6-speed cam plate
- New selector forks
- No kick start available with this conversion

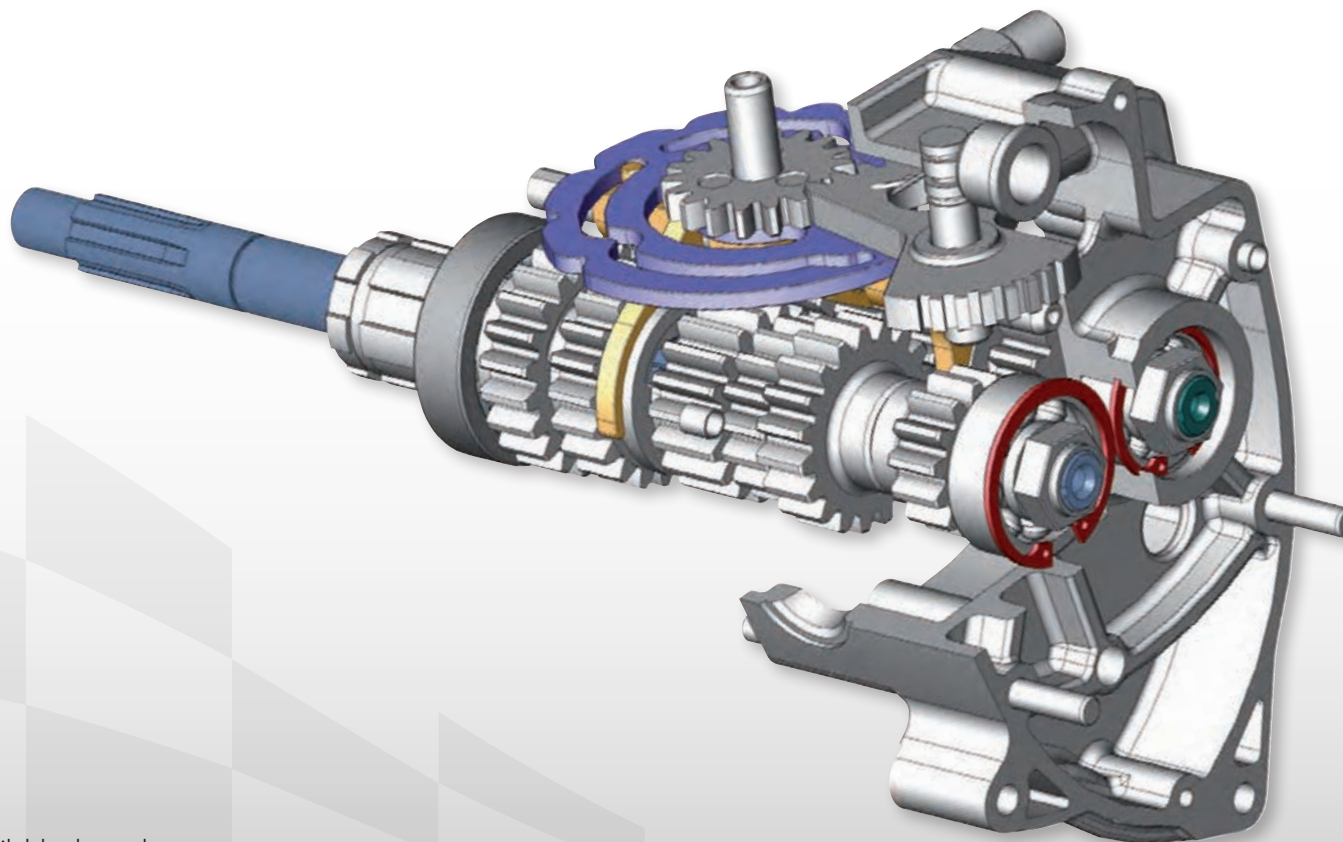

#### Gear Ratios

1st	2nd	3rd	4th	5th	6th
2.200	1.750	1.478	1.253	1.120	1.000

Part no.

QMCA1B

QMCA2B

QMCA5B

£POA

Products available through:  
**Richard Peckett Motorcycles**

Tel: +44 (0) 20 8847 1711

Fax: +44 (0) 20 8758 1403

## Velocette 5-Speed Gearkit

The Quaife QMCA1V gearkit is designed to convert the original Velocette Venom, KTT Mk VII, VIII, Pre War MSS and Mk II KSS Prefix 12 gearboxes from 4-speed to 5-speed.

The Quaife QMCA1V Velocette gearkit is supplied with all necessary components including uprated selector forks and cam plate. Customers have a choice of normal or reverse operation camplates and three ratio choices, covering road and race options.

Key technical features of the Quaife QMCA1V Velocette gearkit include:-

- Converts original 4-speed gearbox to modern 5-speed unit
- High-strength gearchange components
- Optimised gear ratios for road or race use
- Choice of normal or reverse camplates

### Gear Ratios

1st	2nd	3rd	4th	5th	
2.006	1.597	1.278	1.100	1.000	Race
2.437	1.760	1.363	1.145	1.000	Road
2.086	1.660	1.329	1.144	1.000	Race



Part no.  
**QMCA1V**  
**£POA**

Products available through:  
**DDSL**  
Tel: +44 (0) 1255 830 355  
Email: sales@deltadesignsystems.co.uk  
Web: www.deltadesignsystems.co.uk

## Vincent Twin Cylinder 5-Speed Gearkit

The Quaife QMCA1E gearkit is designed to fit the Vincent gearbox fitted to all twin cylinder Vincent models and converts the 4-speed unit to a modern, 5-speed design, ideal for racing, trackdays or fast cruising.

Supplied with uprated selector forks, Quaife designed camplate and modern, dog engagement gears with a high-strength tooth profile, QMCA1E features two ratio options on first gear.

### Gear Ratios

1st	2nd	3rd	4th	5th
2.070	1.611	1.342	1.134	1.000
2.255				



Part no.  
**QMCA1E**  
**£POA**

Products available through:  
**Sports Power**  
Tel: +44 (0) 1732 865 496  
Email: amanda@johnsurtees.com

### Alfa Romeo 5-speed complete gearkit

- 5-speed synchromesh gearkit
- Helical gears
- Close ratio
- Includes input shaft, mainshaft, layshaft and reverse gear
- Includes all new Ford synchromesh parts, selector forks and bearings
- Fits in standard casings with standard gearchange
- Optional Quaife ATB & Tran-X LSD differential



#### Gear Ratios

1st	2nd	3rd	4th	5th
2.303	1.579	1.206	1.000	0.860

Part no.  
**QKE3D**  
**£POA**

Products available through:  
**Furiani Racing**  
Tel: +49 (0) 223 415 757  
Email: info@furiani.de  
Web: www.furiani.de

### Alfa Romeo 5-speed gearkit

- 5-speed synchromesh gearkit
- Helical gears
- Close ratio
- Includes input shaft, mainshaft, layshaft and reverse gear
- Fits in standard casings with standard gearchange
- Uses all original synchromesh parts
- Optional Quaife ATB & Tran-X LSD differential



#### Gear Ratios

1st	2nd	3rd	4th	5th
2.476	1.667	1.222	1.000	0.857

Part no.  
**QKE4D**  
**£POA**

Products available through:  
**Alfaholics**  
Tel: +44 (0) 1275 349 449  
Email: mail@alfaholics.com  
Web: www.alfaholics.com

### Austin Healey 3000 4-Speed Gearkit

- 4-speed synchromesh gearkit
- Straight cut, close ratio gears
- Optional Quaife mainshaft
- Optional Quaife 1st/2nd & 3rd/4th hubs and sliders
- Optional Quaife ATB & Tran-X LSD differential



#### Gear Ratios

1st	2nd	3rd	4th
2.640	1.880	1.430	1.000
2.413	1.722	1.254	1.000

Part no.  
**QKE13A**  
**£POA**

Mainshaft (Direct replacement for original)

E13A1-22	<b>£POA</b>
1st-2nd synchro hub & slider E13A1-23/30	<b>£POA</b>
3rd-4th synchro hub & slider E13A1-31/32	<b>£POA</b>

**Order now:**  
Tel: +44 (0)1732 741144  
Fax: +44 (0)1732 741555  
Email: info@quaife.co.uk  
Web: www.quaife.co.uk



### Austin Rover Mini / Metro 4-Speed Synchro (Remote and A+ Type)

- Straight cut, close ratio gearkit
- Now with coated gears for added durability
- Optional Pot Joint Quaife ATB differential
- Optional Salisbury replacement Quaife ATB & Tran-X LSD differential

#### Gear Ratios

1st	2nd	3rd	4th	
2.544	1.731	1.259	1.000	Remote
2.877	1.827	1.329	1.000	A+ Type
2.544	1.731	1.259	1.000	A+ Type

### Austin Rover Mini 4-Speed Dog Engagement

- Straight cut, close ratio dog engagement gearkit
- Latest 4 dog, open face design
- Needle roller bearings support free running gears
- Aluminium bronze super strong selector forks for rod change gearbox
- Hardened steel selector forks for remote gearbox
- Optional Pot Joint Quaife ATB differential
- Optional Salisbury replacement Quaife ATB & Tran-X LSD differential

#### Gear Ratios

1st	2nd	3rd	4th
2.362	1.564	1.193	1.000
2.143	1.486	1.193	1.000
1.692	1.441	1.197	1.000



Part no.  
QKE3A (Remote)  
£POA

QKE5A (A+)  
£POA

Products available through:  
**Swiftune Engineering**  
Tel: +44 (0) 1233 850 843  
Email: sales@swiftune.co.uk  
Web: www.swiftune.co.uk

Part no.  
QKE15A  
£POA

## Ford Rocket (Type E) Clubman Synchro

- Straight cut, close ratio gears
- Layshaft assembled using separate gears
- Retains original Ford mainshaft
- Maximum recommended power – 190bhp / 7500rpm
- Optional alloy maincase, alloy top cover, gear lever, steel baulk rings and heavy duty operating block available (see page 46-49)
- Alternative ratios available £POA
- Optional Quaife ATB & Tran-X LSD differential

## Gear Ratios

1st	2nd	3rd	4th	
2.480	1.690	1.210	1.000	Rally / Race
2.480	1.690	1.610	1.000	Hot Rod
2.290	2.070	1.950	1.000	BRiSCA F2
3.030	2.070	1.950	1.000	Spedeworth

## Ford Rocket (Type E) Heavy Duty Synchro

- Needle roller bearings support free running gears
- Includes Quaife mainshaft and alloy top cover
- Straight cut close ratio gears
- Layshaft assembled using separate gears
- Choice of input shaft lengths
- Large choice of ratios
- Maximum recommended power – 250 bhp
- Optional alloy maincase, gear lever, steel baulk rings, heavy duty operating block and short tailcase available (see pages 46-49)
- Alternative ratios available £POA
- Standard main case will require modification, must be used with HD layshaft
- Optional Quaife ATB & Tran-X LSD differential

## Gear Ratios

1st	2nd	3rd	4th	5th	
2.390	1.690	1.340	1.000		Rally
2.040	1.540	1.210	1.000		Race
2.390	1.690	1.610	1.000		Hot Rod
1.830	1.380	1.140	1.000		Ultra Close
2.200	1.540	1.210	1.000		Rallycross

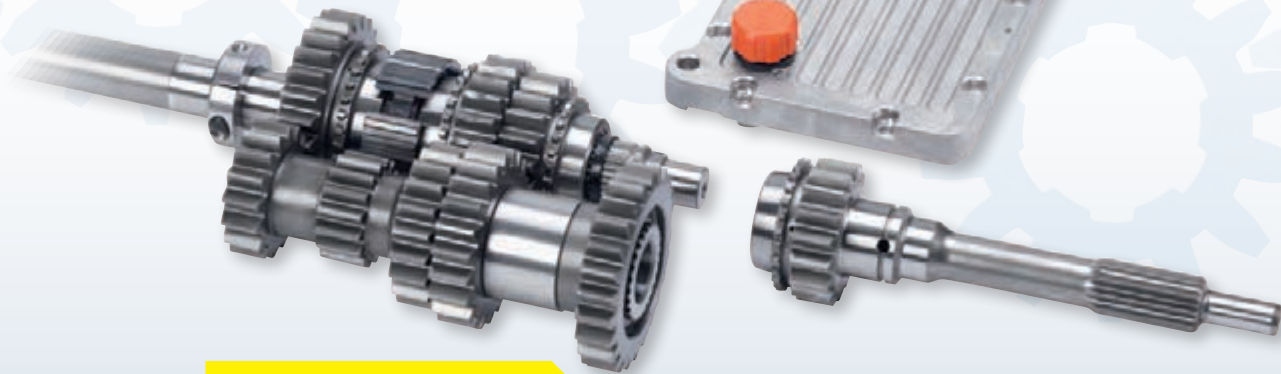

Ford RWD

Part no.  
**QKE6Z**  
**£630.00**

Part no.  
**QKE2Z**  
**£995.00**

### Order now:

Tel: +44 (0)1732 741144

Fax: +44 (0)1732 741555

Email: [info@quaife.co.uk](mailto:info@quaife.co.uk)

Web: [www.quaife.co.uk](http://www.quaife.co.uk)

## Ford Sierra (Type 9) 5-Speed Clubman Synchro Gearkit

- Straight cut close ratio gears
- Layshaft assembled using separate gears
- Retains original Ford mainshaft
- Choice of input shaft length
- Maximum recommended power – 190bhp / 7500rpm
- Helical version also available
- Optional alloy case, alloy top cover, gear lever, steel baulk rings and heavy duty operating block available (see pages 46-49)
- Alternative ratios available £POA
- Optional Quaife ATB & Tran-X LSD differential

### Gear Ratios

1st	2nd	3rd	4th	5th
2.040	1.540	1.210	1.000	0.870
2.200	1.690			0.930
2.390				
2.745				

## Ford Sierra (Type 9) 5-Speed Heavy Duty Synchro

- Needle roller bearings support free running gears
- Includes Quaife mainshaft
- Straight cut, close ratio gears
- Layshaft assembled using separate gears
- Choice of input shaft length
- Maximum recommended power – 250bhp
- Optional alloy case, gear lever, steel baulk rings and heavy duty operating block available (see pages 46-49)
- Alternative ratios available £POA
- Optional Quaife ATB & Tran-X LSD differential

### Gear Ratios

1st	2nd	3rd	4th	5th
2.040	1.540	1.210	1.000	0.870
2.200	1.690			0.930
2.390				



Part no.

**QKE13Z**

**£865.00**

Semi-helical synchromesh gearkit

**QKE24Z      £1,035.00**

### Order now:

Tel: +44 (0)1732 741144  
 Fax: +44 (0)1732 741555  
 Email: info@quaife.co.uk  
 Web: www.quaife.co.uk

Part no.

**QKE15Z**

**£1,310.00**

Semi-helical synchromesh gearkit

**QKE31Z      £1,480.00**



### Ford Bullet (2000E) Synchro

- Straight cut, close ratio gears
- Needle roller bearings support free running gears
- Includes Quaife mainshaft
- Larger, Rocket sized spigot bearing
- Optional steel baulk rings available
- Standard length or short mainshaft
- Optional Quaife ATB & Tran-X LSD differential
- Only fits 3 rail gearbox
- Can be fitted to Type 3 gearbox but with Ford Escort / Lotus Elan style short input only

### Gear Ratios

1st	2nd	3rd	4th
2.250	1.495	1.168	1.000
2.500	1.660	1.220	1.000

### Ford Bullet (2000E) Dog Engagement

- Dog engagement for faster gear change
- Straight cut, close ratio gears
- Needle roller bearings support free running gears
- Includes Quaife mainshaft
- Larger, Rocket sized spigot bearing
- Optional Quaife ATB & Tran-X LSD differential

### Gear Ratios

1st	2nd	3rd	4th
2.250	1.495	1.168	1.000
2.500	1.660	1.220	1.000



Part no.  
QKE3Z  
£935.00

Part no.  
QKE18Z  
£POA

Products available through:  
**Tony Thompson Racing**

Tel: +44 (0) 1664 812454

Fax: +44 (0) 1664 813192

Email: [info@tonythompsonracing.co.uk](mailto:info@tonythompsonracing.co.uk)

## Ford Escort Sport (Type 2) Synchro

- Straight cut, close ratio gears
- Layshaft assembled using separate gears
- Retains original Ford mainshaft
- Optional Quaife ATB & Tran-X LSD differential

### Gear Ratios

1st	2nd	3rd	4th
2.500	1.640	1.220	1.000



## Borg Warner T5 Synchro

- 5-speed synchromesh gearkit
- Helical gears
- Layshaft 5th gear redesigned to use needle bearing
- Cosworth and TVR options
- Standard and close ratios available
- Retains original mainshaft
- Includes strengthened selector forks (available separately to use with standard gearkit)
- Optional Quaife ATB differential

### Gear Ratios

1st	2nd	3rd	4th	5th	
2.915	1.932	1.323	1.000	0.795	STD
2.527	1.675	1.259	1.000	0.867	Close



Part no.  
**QKE12Z**  
**£810.00**

### Order now:

Tel: +44 (0)1732 741144  
Fax: +44 (0)1732 741555  
Email: [info@quaife.co.uk](mailto:info@quaife.co.uk)  
Web: [www.quaife.co.uk](http://www.quaife.co.uk)

Part no.  
**QKE40Z**  
**£POA**

Products available through:  
**Gearbox Man**  
Tel: +44 (0) 1582 840008  
Email: [info@gearboxman.com](mailto:info@gearboxman.com)

## 2000E 4-speed 'Bullet' Gearbox

Refer to page 64

Fitted to:

- Cortina Mk1
- Lotus Cortina Mk1/2 -68
- Escort RS1600 / Mexico
- Escort Twin Cam



## Type 2 4-speed Sport Gearbox

Refer to page 65

Fitted to:

- All Mk1/2 Escorts excluding RS / Mexico and Twin Cam



## Type E 4-speed Rocket Gearbox

Refer to page 42/43 & 62

Fitted to:

- Capri 1.6 / 2.0 82 on
- Cortina Mk3 2.0
- Cortina Mk4/5 1.6GT / 2.0 / 2.3
- Escort RS2000 Mk1/2
- Escort RS Mexico Mk2
- Sierra 1.6 / 2.0



## Type 9 5-speed Sierra Gearbox

Refer to page 44/45 & 63

Fitted to:

- Capri 1.6 / 2.0 02 / 83 on
- Capri 2.8 11 / 82 on
- Sierra 1.6 / 1.8 / 2.0 to 12 / 88
- Sierra XR4i



## MT75 5-speed Gearbox

Refer to page 41

Fitted to:

- Sapphire / Escort Cosworth 4WD
- Sierra / Granada 2.9 4WD



## Borg Warner T5 5-speed Gearbox

Refer to page 65

Fitted to:

- Sierra / Sapphire
- Cosworth 2WD



## Type IB5 5-speed Gearbox

Refer to page 34 & 67/68

Fitted to:

- Ka
- Focus 1.4 / 1.6 / 1.8
- Fiesta
- Puma
- Escort Mk6



## MTX75 5-speed Gearbox

Refer to page 69

Fitted to:

- Escort Mk5/6 130PS
- Escort Mk5/6 RS2000
- Mondeo
- Focus 1.8D / 2.0 / RS (not ST170)





Quaife now offers two exciting transmission upgrades for users of the Ford IB5 gearbox fitted to the Ford Fiesta, Focus, Puma and Ka Mk1, which transforms the performance of these cars. In addition to the 5-speed sequential gearkit (QKE38Z see Page 37) Quaife has developed a 5-speed 'H-pattern,' close-ratio dog engagement gearkit for the IB5 transmission, for customers requiring a non-sequential transmission option.

Carrying part number QKE35Z, the gearkit is designed for easy installation into the standard Ford IB5 gearbox casing without modifications. Technical highlights include close-ratio, straight-cut gears to minimise transmission power losses and enable drivers to keep the engine working in its power band at all times. An open face dog design allows ultra fast gearshifts and QKE35Z includes a set of Quaife designed uprated gear selectors that ensure durability from the shift mechanism.

The combination of close-ratios, straight-cut gears and rapid dog engagement selection makes the QKE35Z IB5 5-speed gearkit the perfect choice for Ford owners seeking an advanced, reliable motorsport transmission solution. Quaife offers a choice of seven different final drive options, covering all potential motorsport, trackday and fast road use requirements.

Key technical features of the QKE35Z Ford IB5 5-speed dog engagement gearkit include:-

- Open face dog engagement for fast gearchanges
- Straight-cut, close-ratio gears
- Installs into stock IB5 gear casing
- Quaife selector forks included in kit
- Large choice of final drive ratios
- Optional Quaife ATB & Tran-X LSD differential



### Gear Ratios

1st	2nd	3rd	4th	5th
2.580	1.870	1.420	1.130	1.040
				0.920

### Final Drive Ratios

3.857	4.083	4.380	4.540	4.690	4.910	5.080
-------	-------	-------	-------	-------	-------	-------

### Order now:

Tel: +44 (0)1732 741144  
 Fax: +44 (0)1732 741555  
 Email: info@quaife.co.uk  
 Web: www.quaife.co.uk

Part no.  
**QKE35Z**  
**£3,155.00**

Additional final drive ratio  
**QRE35Z £625.00**

## Ford Fiesta / Escort / Orion 5-Speed Synchro (BC Type)

- Complete gearkit, including input and output shafts
- Straight cut, close ratio gears
- All output shaft gears run on needle roller bearings
- Alternative 1st, 2nd, 4th and 5th gear ratios
- May require an operating arm on post 1987 gearboxes (additional cost)
- Large range of final drive ratios
- Turbo, large synchro type also available
- Optional Quaife ATB & Tran-X LSD differential
- Maximum recommended power – 175bhp

### Gear Ratios

1st	2nd	3rd	4th	5th
2.580	1.870	1.420	1.190	1.040
2.153	1.733		1.130	0.960
				0.920

### Final Drive Ratios

3.313	3.857	4.083	4.380	4.540	4.690	4.910
5.080						

## Ford KA / Puma / Focus / Fiesta ST150 5-Speed Synchro (IB5 Type)

- Used with latest type synchromesh
- Complete gearkit, including input and output shafts
- Straight cut, close ratio gears
- All output shaft gears run on needle roller bearings
- Alternative 5th gear ratio
- Optional Quaife ATB & Tran-X LSD differential

### Gear Ratios

1st	2nd	3rd	4th	5th
2.580	1.870	1.420	1.130	1.040
				0.960
				0.920

### Final Drive Ratios

3.857	4.083	4.380	4.540	4.690	4.910	5.080
-------	-------	-------	-------	-------	-------	-------



Ford FWD

Part no.

**QKE16Z**

**£1,580.00**

Additional final drive ratio  
**QRE16Z**      **£625.00**

Modified customers' operating arm      **£POA**

Part no.

**QKE25Z**

**£1,580.00**

Additional final drive ratio  
**QRE25Z**      **£625.00**

### Order now:

Tel: +44 (0)1732 741144

Fax: +44 (0)1732 741555

Email: [info@quaife.co.uk](mailto:info@quaife.co.uk)

Web: [www.quaife.co.uk](http://www.quaife.co.uk)

## Ford Escort / Mondeo MTX75 5-Speed Synchro

- 5-speed synchromesh gearkit
- Helical gears
- Needle roller bearings support free running gears
- Final drive ratio included
- Optional strengthened selector forks
- Optional Quaife ATB differential
- **Option for 3rd gear – choice between early 3 piece synchro & later 1 piece synchro. Please specify with order.**

### Gear Ratios

1st	2nd	3rd	4th	5th
2.643	1.824	1.400	1.130	0.962

### Final Drive Ratios

3.625	3.824	4.062	4.250	4.600	4.857
-------	-------	-------	-------	-------	-------

## Ford Escort / Focus / Mondeo MTX75 Dog Engagement

- Straight cut, close ratio gears
- Needle roller bearings support free running gears
- Choice of 1st gear ratios
- Final drive ratio included
- Comprehensive kit – includes selectors
- Optional Quaife ATB differential
- For fitment to Escort, shorten input shaft by 11mm

### Gear Ratios

1st	2nd	3rd	4th	5th
2.462	1.824	1.400	1.182	1.040
2.643				0.920

### Final Drive Ratios

3.625	3.823	4.062	4.250	4.600	4.857
-------	-------	-------	-------	-------	-------



Part no.  
**QKE28Z**  
**£1,865.00**

Additional final drive ratio  
**QRE28Z £625.00**

### Order now:

Tel: +44 (0)1732 741144  
Fax: +44 (0)1732 741555  
Email: info@quaife.co.uk  
Web: www.quaife.co.uk

Part no.  
**QKE29Z**  
**£3,075.00**

Including final drive ratio and turret  
**QKE29Z £3,525.00**  
Additional final drive ratio  
**QRE28Z £625.00**



### Honda Civic 5-Speed Synchro

- 5-speed synchromesh gearkit
- Close ratio, semi-helical gears
- Range of final drive ratios
- Final drive ratio included
- Optional Quaife ATB differential
- Suitable for gearbox codes Y21, Y80, S80 & S4C
- To fit EK4 with QDF1U ATB differential
- To fit EK9 117mm crownwheel must be modified

### Gear Ratios

1st	2nd	3rd	4th	5th
2.462	1.813	1.500	1.250	1.045

### Final Drive Ratios

3.786	4.154	4.500	4.750
-------	-------	-------	-------

### Honda Civic 5-Speed Dog Engagement

- 5-speed dog engagement gearbox
- Straight-cut, close-ratio gears
- Latest four-dog design for rapid shifts
- Choice of included final drives
- Comes with Quaife selector forks
- Optional Quaife ATB differential
- FIA homologated ratios
- Must be used with latest welded rod selector (EK9/DC2 Type-R)
- Suitable for gearbox codes Y21, Y80, S80 & S4C

### Gear Ratios

1st	2nd	3rd	4th	5th
2.428	1.813	1.421	1.174	1.000

### Final Drive Ratios

5.545	5.700	5.818
-------	-------	-------

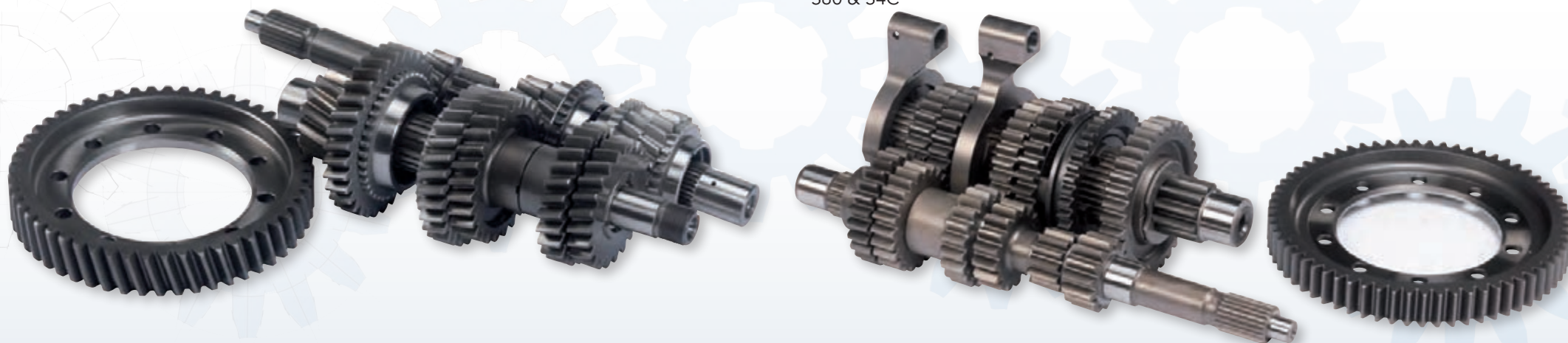

Honda

Part no.

**QKE2J**

**£1,825.00**

Additional final drive ratio  
QRE2J £625.00

Part no.

**QKE6J**

**£3,075.00**

Additional final drive ratio  
QRE6J £625.00

### Order now:

Tel: +44 (0)1732 741144

Fax: +44 (0)1732 741555

Email: [info@quaife.co.uk](mailto:info@quaife.co.uk)

Web: [www.quaife.co.uk](http://www.quaife.co.uk)

## R380 4x4 Transmission 5-Speed Synchro

- 5-speed synchromesh gearkit for R380 4x4 gearbox
- Straight cut, close ratio
- Quaife mainshaft included
- Optional steel baulk rings
- Optional Quaife ATB differential
- Now fits metric input bearing

### Gear Ratios

1st	2nd	3rd	4th	5th
2.424	1.759	1.303	1.000	0.913

## Morgan / Moss Plus4 and pre-72 Plus8 4-speed Synchro Helical Gearkit

- Direct replacement for original 4-speed Morgan road gearkit
- 22mm wide Helical gears
- New high-strength steel selector forks
- Modern, well-proven synchromesh engagement
- Replacement layshaft spindle
- Uses standard gearshift mechanism
- Optional Quaife ATB differential

### Gear Ratios

1st	2nd	3rd	4th
2.480	1.564	1.197	1.000

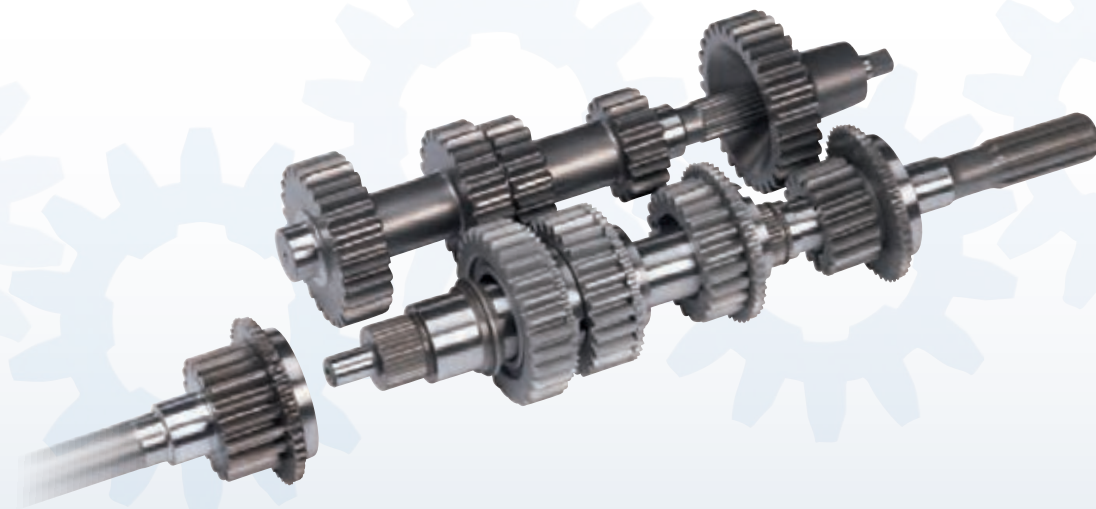

Part no.  
**QKE2R**  
**£POA**

Products available through:  
**Ashcroft Transmissions**  
Tel: +44 (0) 1582 496040  
Email: [info@ashcroft-transmissions.co.uk](mailto:info@ashcroft-transmissions.co.uk)

Part no.  
**QKE3Q**  
**£POA**

Products available through:  
**JB Sports Engineering**  
Tel: +44 (0) 7932 045693  
Email: [info@jb-engineering.co.uk](mailto:info@jb-engineering.co.uk)

**Rover 220 & MGF (PG1) 5-Speed Synchro**

- Complete 5-speed synchromesh gearkit
- Straight cut, close ratio gears
- Can be used with original final drive
- Optional Quaife final drive and choice of 1st gear ratios
- Optional Quaife ATB differential

**Gear Ratios**

1st	2nd	3rd	4th	5th
3.000	1.937	1.556	1.273	1.043
2.615				

**Final Drive Ratios**

3.923	4.214	4.462
-------	-------	-------

**Rover 220 & MGF (PG1) 5-Speed Dog Engagement**

- Complete 5-speed dog engagement gearkit
- Straight cut, close ratio gears
- Choice of final drive ratios
- Optional Quaife ATB differential
- Includes selector forks

**Gear Ratios**

1st	2nd	3rd	4th	5th
2.417	1.923	1.533	1.278	1.050

**Final Drive Ratios**

3.923	4.214	4.462	4.917	5.167
-------	-------	-------	-------	-------



Part no.

**QKE3R****£1,135.00**Quaife final drive ratio  
(not included)**QRE3R      £625.00**

Part no.

**QKE5R****£3,165.00**

Additional final drive ratio

**QRE5R   £625.00****Order now:**

Tel: +44 (0)1732 741144

Fax: +44 (0)1732 741555

Email: [info@quaife.co.uk](mailto:info@quaife.co.uk)Web: [www.quaife.co.uk](http://www.quaife.co.uk)



## Lotus Elise / Exige (PG1) 6-Speed Synchro

- New 6-speed synchromesh gearkit
- Helical, close ratio gears
- Choice of final drive ratios
- Includes new strengthened outer casing
- Optional Quaife ATB differential

### Gear Ratios

1st	2nd	3rd	4th	5th	6th
3.125	2.143	1.640	1.276	1.030	0.861

### Final Drive Ratios

3.647	3.955
-------	-------

## Lotus Elise / Exige (PG1) 6-Speed Dog Engagement

- New 6-speed dog engagement gearbox
- Straight cut close ratio gears
- Choice of final drive ratios
- Includes new strengthened outer casing and selector forks
- Optional Quaife ATB differential

### Gear Ratios

1st	2nd	3rd	4th	5th	6th
2.583	2.071	1.688	1.412	1.200	1.048

### Final Drive Ratios

3.923	4.214	4.462
-------	-------	-------



Part no.

**QKE4R**

**£3,710.00**

Additional final drive ratio  
**QRE4R £655.00**

**Order now:**

Tel: +44 (0)1732 741144

Fax: +44 (0)1732 741555

Email: [info@quaife.co.uk](mailto:info@quaife.co.uk)

Web: [www.quaife.co.uk](http://www.quaife.co.uk)

Part no.

**QKE6R**

**£3,845.00**

Additional final drive ratio  
**QRE6R £655.00**

## To suit Lotus Elan and similar

- Direct replacement for very rare 1950s ZF 4-speed gearkit
- Available with helical or straight-cut gears
- 17.5mm wide gears running on high-quality needle roller bearings
- Modern, well-proven synchromesh engagement
- Includes replacement reverse idler running on needle roller bearings
- Race-winning gearkit in major international events

## QKD3V Gear Ratios – Helical

1st	2nd	3rd	4th
2.363	1.643	1.176	1.000

## QKD4V Gear Ratios – Straight Cut

1st	2nd	3rd	4th
2.363	1.643	1.176	1.000



## Order now:

Tel: +44 (0)1732 741144

Fax: +44 (0)1732 741555

Email: [info@quaife.co.uk](mailto:info@quaife.co.uk)

Web: [www.quaife.co.uk](http://www.quaife.co.uk)

## Mazda MX5 (Miata) 5-Speed Synchro

- Complete 5-speed synchro gearkit
- Helical close ratio gears
- Fits 3-part synchro boxes, '94 onwards
- Optional Quaife ATB differential

### Gear Ratios

1st	2nd	3rd	4th	5th
2.564	1.670	1.273	1.000	0.794
2.345	1.544	1.222	1.000	0.868

## Mazda RX7 5-Speed Synchro

- Complete 5-speed synchro gearkit
- Helical close ratio gears
- Non-turbo engines
- Optional Quaife ATB differential

### Gear Ratios

1st	2nd	3rd	4th	5th
2.345	1.544	1.222	1.000	0.868
2.564	1.670	1.273	1.000	0.794



Part no.  
**QKE3K**  
**£1,610.00**

### Order now:

Tel: +44 (0)1732 741144  
 Fax: +44 (0)1732 741555  
 Email: [info@quaife.co.uk](mailto:info@quaife.co.uk)  
 Web: [www.quaife.co.uk](http://www.quaife.co.uk)

Part no.  
**QKE4K**  
**£1,610.00**



### MG Midget 4-Speed Dog Engagement Gearkit

- Complete 4-speed open face dog engagement gearkit
- Dog engagement on all gears
- Straight cut, close ratio gears
- Includes selector forks
- Optional Quaife ATB & Tran-X LSD differential

#### Gear Ratios

1st	2nd	3rd	4th
2.573	1.660	1.195	1.000



### Mini Cooper S 6-Speed Dog Engagement

- 6-speed dog engagement gearkit for fitment within the standard Getrag 285 gearbox
- Semi helical / close ratio gears
- Final drive ratios included
- Three ratio options for fast road, race and rally use
- Optional Quaife ATB & Tran-X LSD differential

#### Gear Ratios

1st	2nd	3rd	4th	5th	6th	
3.846	2.588	1.875	1.543	1.250	1.029	Road FD 2.733
3.846	2.737	2.126	1.711	1.367	1.100	Race FD 3.000
3.846	2.737	2.148	1.729	1.367	1.000	Rally FD 3.409



Part no.  
**QKE14A**  
**£POA**

#### Order now:

Tel: +44 (0)1732 741144  
 Fax: +44 (0)1732 741555  
 Email: [info@quaife.co.uk](mailto:info@quaife.co.uk)  
 Web: [www.quaife.co.uk](http://www.quaife.co.uk)

Part no.  
**QKE34Z**  
**£2,925.00**

## Mitsubishi Lancer Evo 5/6/7/8/9 5-Speed Dog Engagement

- Complete 5-speed dog engagement gear kit
- Homologated Gp N ratios
- Includes final drive
- Wider gears for extra strength
- Optional Quaife ATB differential

### Gear Ratios

1st	2nd	3rd	4th	5th
3.000	2.000	1.470	1.111	0.857

### Final Drive Ratios

4.307

## Mitsubishi Lancer Evo 8MR 5-Speed Dog Engagement

- Complete 5-speed dog engagement gearkit
- Converts 6-speed to homologated Gp N ratios
- Includes final drive
- Optional Quaife ATB differential

### Gear Ratios

1st	2nd	3rd	4th	5th
3.000	2.000	1.470	1.111	0.857

### Final Drive Ratios

4.307



Part no.  
**QKE3U**  
**£3,670.00**

**Order now:**  
Tel: +44 (0)1732 741144  
Fax: +44 (0)1732 741555  
Email: [info@quaife.co.uk](mailto:info@quaife.co.uk)  
Web: [www.quaife.co.uk](http://www.quaife.co.uk)

Part no.  
**QKE4U**  
**£4,175.00**

### Nissan Silvia 5-speed dog engagement

- Complete 5-speed dog engagement gearkit with 1:1 top gear
- Straight cut, close ratio
- Comprehensive kits – includes selectors and gear lever
- 'H' pattern gearchange
- Optional Quaife ATB differential
- Fits both S13 & S14, but S13 requires casing mods to sandwich plate

### Gear Ratios

1st	2nd	3rd	4th	5th
2.762	1.961	1.533	1.212	1.000

### Nissan Sunny / Pulsar GTiR 5-Speed Synchro (4WD Only)

- Complete 5-speed synchromesh gearkit
- Helical, close ratio gears
- Kit includes input shaft
- Retains original final drive ratio

### Gear Ratios

1st	2nd	3rd	4th	5th
2.615	1.765	1.238	0.917	0.741



Nissan

Part no.  
QKE6F  
£3,160.00

Part no.  
QKE8F  
£2,210.00

### Order now:

Tel: +44 (0)1732 741144  
Fax: +44 (0)1732 741555  
Email: [info@quaife.co.uk](mailto:info@quaife.co.uk)  
Web: [www.quaife.co.uk](http://www.quaife.co.uk)



## Peugeot 106 / Citroën C2 (MA Gearbox) 5-Speed Synchro

- 5-speed synchromesh gearkit
- Helical cut gears
- Quaife close ratio or GpN homologated
- Runs with standard final drive
- Suitable for MA gearbox types
- Now with coated gears for added durability
- Optional Quaife ATB & Tran-X LSD differential
- Citroën C2 5th gear option available

### Gear Ratios

1st	2nd	3rd	4th	5th
2.538	1.765	1.421	1.190	1.043
3.417	2.357	1.800	1.467	1.206



## Peugeot 205 GTi / Citroën ZX 5-Speed Synchro Gearkit (BE3 & Later)

- 5-speed synchromesh gearkit
- Helical gears
- Close ratio
- Optional final drive
- Suitable for BE3 with or without Quaife final drive. BE4 must use Quaife final drive
- Final Drive runs with standard gears
- Optional Quaife ATB & Tran-X LSD differential

### Gear Ratios

1st	2nd	3rd	4th	5th
2.692	1.933	1.444	1.143	0.957

### Final Drive Ratios

4.400 4.785

Peugeot 205 5-speed synchromesh gearkit (without crownwheel & pinion)  
**QKE5H000** £1,425.00

Additional crownwheel & pinion  
**QRE5H** £625.00



Part no.  
**QKE4H**  
**£1,400.00**

### Order now:

Tel: +44 (0)1732 741144  
Fax: +44 (0)1732 741555  
Email: [info@quaife.co.uk](mailto:info@quaife.co.uk)  
Web: [www.quaife.co.uk](http://www.quaife.co.uk)

Part no.  
**QKE5H**  
**£1,880.00**

## Citroën Saxo VTS / Peugeot 106 GTI / MG-ZR 5-Speed Dog Engagement Gearkit

The Quaife QKE7H dog engagement gearkit is designed to maximise the transmission performance of the MA gearbox fitted to these Citroën and Peugeot models, used in numerous motorsport disciplines.

Wider than standard straight-cut, close-ratio gears with the latest four-dog engagement mechanism ensure ultra-fast gearchanges and excellent reliability. Two gear ratio sets plus a choice of five different final drives make the Quaife QKE7H dog engagement gearkit for the Citroën / Peugeot MA gearbox a must have for the 106 GTI and Saxo VTS used in competition. Please note, this kit includes a Quaife ATB helical gear limited slip differential and requires Rover-type selector rods.

Key features of the Quaife QKE7H Citroën / Peugeot MA 5-speed dog engagement gearkit include:-

- Straight-cut, close-ratio gears
- Wider than standard gears for improved durability
- Dog engagement gears for rapid shifts
- Large choice of final drives for race, rally and trackday use
- Kit includes Quaife ATB helical gear limited slip differential
- Optional Tran-X plate diff available

## Gear Ratios

1st	2nd	3rd	4th	5th
3.417	2.333	1.778	1.429	1.120
3.100	2.333	1.778	1.429	1.235

## Final Drive Ratios

3.571	3.923	4.143	4.538	4.857
-------	-------	-------	-------	-------



Part no.

**QKE7H**

**£3,705.00**

(Including final drive ratio and ATB differential)

Additional final drive ratios  
£POA

Quaife ATB differential end cover to suit above QDF10H  
£POA

End cover with final drive for plate type differential  
£POA

Rover selector rods  
1625 / 1626  
£125.00

## Order now:

Tel: +44 (0)1732 741144

Fax: +44 (0)1732 741555

Email: [info@quaife.co.uk](mailto:info@quaife.co.uk)

Web: [www.quaife.co.uk](http://www.quaife.co.uk)

## Renault UN1 (Lotus Esprit V8) Helical Gearkit (Upgrade KIT)

- Both Esprit V8 and GT40 Replica splines available
- Optional Quaife ATB differential

### Gear Ratios

1st	2nd	3rd	4th	5th
2.667	1.750	Std	Std	Std

## Renault 5 tour de course / maxi gearkit (UN1/ 369)

- 5-speed synchromesh gearkit
- Helical gears
- Strengthened input shaft
- Retains original Crownwheel & pinion (not included in kit)
- Retains original ratios
- Direct replacement for original parts
- Optional Quaife ATB differential

### Gear Ratios

1st	2nd	3rd	4th	5th
3.250	2.235	1.619	1.250	1.036



Part no.  
**QKE3W**  
**£POA**

Part no.  
**QKE4W**  
**£POA**

Products available through:  
**GTO Racing**  
Tel: +44 (0) 118 9401101  
Email: gtoracing2001@yahoo.co.uk



### Subaru Impreza 5-Speed Synchro Gearkit

- Complete 5-speed synchromesh gearkit
- Fits only 1993/98 gearbox models
- Group N ratios with semi-helical gear teeth
- Includes Quaife input shaft
- Retains original final drive
- Optional Quaife ATB differential

#### Gear Ratios

1st	2nd	3rd	4th	5th
3.454	2.333	1.750	1.354	0.972

### Subaru Impreza 5-Speed Dog Engagement Gearkit

- Complete 5-speed dog engagement gearkit
- Fits only 1993-1999 gearbox models with idler E4Y1-06
- Fits 1999 on with idler E3Y1-18
- Does not fit 2003 Type 75 gearboxes
- Straight cut gears
- Group N or Clubman ratios
- Includes Quaife quill input shaft
- Retains original final drive
- Optional Quaife ATB differential

#### Gear Ratios

1st	2nd	3rd	4th	5th	
2.917	2.090	1.556	1.176	0.900	GpN
2.917	2.090	1.556	1.250	0.962	Clubman



Subaru

Part no.  
QKE1Y  
£2,505.00

Part no.  
QKE3Y GpN  
QKE4Y Clubman  
£3,935.00

#### Order now:

Tel: +44 (0)1732 741144  
Fax: +44 (0)1732 741555  
Email: [info@quaife.co.uk](mailto:info@quaife.co.uk)  
Web: [www.quaife.co.uk](http://www.quaife.co.uk)

### Saab 6-Speed Synchro Gearkit

- Suitable for vehicles using the (GM) F35 gearbox
- Converts standard box to 6-speed
- 6-speed synchromesh gearkit
- Helical, close ratio gears
- Includes crownwheel & pinion
- Quaife ATB differential

### Gear Ratios

1st	2nd	3rd	4th	5th	6th
3.000	1.933	1.368	1.045	0.833	0.704

### Final Drive Ratio

4.071



Part no.  
**QKE20C**  
**£POA**

### Order now:

Tel: +44 (0)1732 741144  
 Fax: +44 (0)1732 741555  
 Email: info@quaife.co.uk  
 Web: www.quaife.co.uk

### Toyota MR2 Spyder, Celica, Corolla and Lotus Elise / Exige 6-Speed Dog Engagement Gearkit

The Quaife QKE10E gearkit for these Toyota and 2ZZ-GE engined Lotus models features close-ratio gears for circuit, sprint or rally use with dog engagement for ultra-fast gearshifts.

- Straight-cut, close-ratio gears
- Dog engagement gears for rapid shifts
- Large choice of final drives for race, rally and trackday use
- Fits directly into standard Toyota gearbox casing

### Gear Ratios

1st	2nd	3rd	4th	5th	6th
2.545	1.929	1.563	1.333	1.167	1.050
3.200	2.250	1.647	1.368	1.143	0.957

### Final Drive Ratios

3.733 3.857 4.143 4.417 5.000

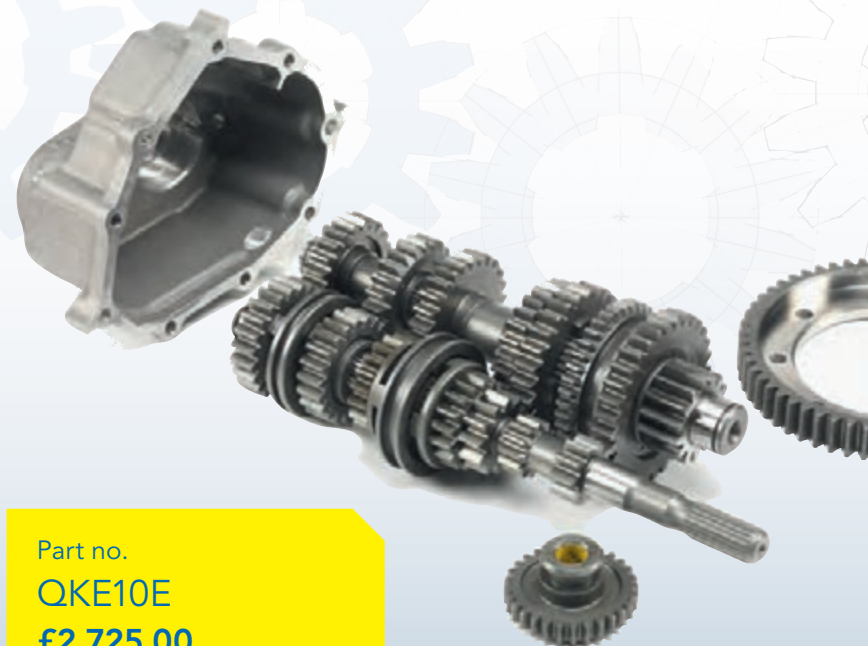

Part no.  
**QKE10E**  
**£2,725.00**

Additional final drive ratios  
**QRE10E £625.00**

### 02A/02J 6-Speed Synchro Gearkit

- Complete 6-speed synchromesh gearkit
- Converts standard box to 6-speed
- Close ratio gears
- High strength semi-helical design
- Fits 02A/02J gearbox in VW, Audi, Seat & Skoda
- Retains original final drive
- Suitable for road or race
- Requires some minor casing modifications
- Includes extended gear casing
- Optional Quaife ATB & Tran-X LSD differential
- Optional selector rod support (15mm or 16mm)

### Gear Ratios

1st	2nd	3rd	4th	5th	6th
2.727	1.929	1.500	1.200	0.956	0.800

### Crownwheel bolt kits

- Genuine ARP replacement bolt sets

#### 020 / 02C Bolt kit

1557 **£115.00**

#### 02A / 02J Bolt kit

F8R206KIT **£115.00**

#### 02M / 02Q Bolt kit

1555 **£145.00**



Part no.

**QKE1V**

**£2,360.00**

Selector rod support  
(both 15mm & 16mm)

**QKE1VROD £70.00**

### 02A/02J 6-Speed Dog Engagement Gearkit

- Complete 6-speed dog engagement gearkit
- Converts standard box to 6-speed
- High strength semi-helical design
- Choice of final drive and 5th & 6th gear ratios
- Requires some minor casing modifications
- Includes selector rod support (15mm or 16mm)
- Includes extended gear casing
- Optional Quaife ATB & Tran-X LSD differential

### Gear Ratios

1st	2nd	3rd	4th	5th	6th
2.417	1.929	1.500	1.200	0.956	0.800
				1.045	0.913

### Final Drive Ratios

3.923 4.167 4.636 5.091



Part no.

**QKE2V**

**£3,105.00**

Additional final drive ratios  
**QRE2V £625.00**

### Order now:

Tel: +44 (0)1732 741144

Fax: +44 (0)1732 741555

Email: [info@quaife.co.uk](mailto:info@quaife.co.uk)

Web: [www.quaife.co.uk](http://www.quaife.co.uk)



## Corsa / Nova F13/F15 5-Speed Synchro

- 5-speed synchromesh gearkit
- Straight cut, close ratio
- Includes crownwheel & pinion
- Choice of final drive ratios
- Fitment to F15 casing requires F13 synchro assemblies (balk rings and synchro hubs)
- Optional Quaife ATB & Tran-X LSD differential
- Optional gearlever and turret available – see page 86

### Gear Ratios

1st	2nd	3rd	4th	5th
2.540	1.760	1.420	1.190	1.040

### Final Drive Ratios

3.933	4.533	4.857
-------	-------	-------

## Corsa / Nova F13/F15 5-Speed Dog Engagement

- 5-speed dog engagement gearkit
- Straight cut, close ratio
- Includes crownwheel & pinion and heavy duty end cover
- Choice of final drive ratios
- Comprehensive kit – includes selectors
- Input shaft – 7/8" 20T spline
- Optional Quaife ATB & Tran-X LSD differential
- Optional gearlever and turret (recommended for dog kits) available – see page 86

### Gear Ratios

1st	2nd	3rd	4th	5th
2.540	1.760	1.420	1.190	1.040

### Final Drive Ratios

4.360	4.530	4.640	4.860	5.170
-------	-------	-------	-------	-------



Part no.

**QKE15C**

**£1,685.00**

Additional final drive ratios

**QRE15C      £625.00**

**Order now:**

Tel: +44 (0)1732 741144

Fax: +44 (0)1732 741555

Email: [info@quaife.co.uk](mailto:info@quaife.co.uk)

Web: [www.quaife.co.uk](http://www.quaife.co.uk)

Part no.

**QKE8C**

**£2,775.00**

Additional final drive ratio

**QRE8C      £625.00**

### Corsa / Nova F13/F15 6-Speed Dog Engagement

- 6-speed dog engagement gearkit
- Converts standard box to 6-speed
- Straight cut, close ratio
- Includes crownwheel & pinion and heavy duty end cover
- Choice of final drive ratios
- Comprehensive kit – includes selectors
- Input shaft – 7/8" 20T spline
- Optional Quaife ATB & Tran-X LSD differential
- Optional gearlever and turret (recommended for dog kits) available

### Gear Ratios

1st	2nd	3rd	4th	5th	6th
2.540	1.930	1.560	1.300	1.140	1.040

### Final Drive Ratios

4.360	4.640	4.860
-------	-------	-------

### F13/F15/F16/F18/F20 Gear Lever Assembly

- Stronger cast alloy housing
- Short throw lever for quicker gear change
- Spherical bearing ensures smooth, positive action
- Hardened, one piece lever for extra strength
- Includes nylon gear knob
- Connecting linkage not supplied
- Strongly recommended for dog kits



### F13/F15/F16/F18/F20 Turret Assembly

- Stronger LM25 alloy housing
- Thicker, stronger bronze operating finger
- One piece steel operating rod
- Connecting linkage not supplied
- Strongly recommended for dog kits

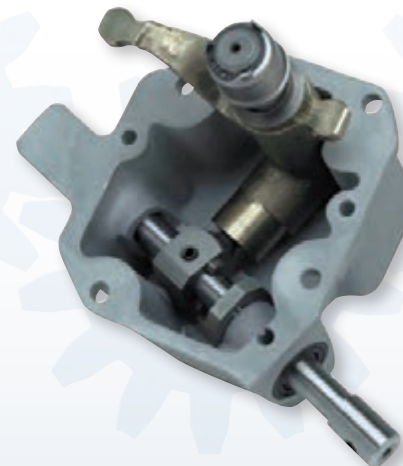

Part no.

**QKE10C**

**£3,815.00**

Additional final drive ratio

**QRE10C      £655.00**

### Order now:

Tel: +44 (0)1732 741144

Fax: +44 (0)1732 741555

Email: [info@quaife.co.uk](mailto:info@quaife.co.uk)

Web: [www.quaife.co.uk](http://www.quaife.co.uk)

Part no.

**QKE6CT Turret**

**£455.00**

**QKE6CG Gear lever**

**£345.00**

## Astra / Kadett F18/F20 5-Speed Synchro

- 5-speed synchromesh gearkit
- Straight cut, close ratio
- Includes crownwheel & pinion
- Choice of final drive and 5th gear ratios
- Final drive can be fitted to standard gearbox
- Optional Quaife ATB & Tran-X LSD differential
- Optional gearlever and turret available – see page 86

### Gear Ratios

1st	2nd	3rd	4th	5th
2.540	1.760	1.420	1.190	1.040
				0.958
				0.870

### Final Drive Ratios

4.200	4.500	4.850	5.180
-------	-------	-------	-------

## Astra / Kadett F16/F18/F20 5-Speed Dog Engagement

- 5-speed dog engagement gearkit
- 2-speed Autograss kit available
- Straight cut, close ratio
- Includes crownwheel & pinion and heavy duty end cover
- Choice of final drive and 1st, 2nd and 5th gear ratios
- Comprehensive kit – includes selectors
- Input shaft – 7/8" 20T spline
- Optional Quaife ATB & Tran-X LSD differential
- Optional gearlever and turret (recommended for dog kits) available – see page 86

### Gear Ratios

1st	2nd	3rd	4th	5th
2.308	1.688	1.389	1.200	1.045
2.910	2.071			0.970

### Final Drive Ratios

3.190	3.550	3.740	3.940	4.200	4.500
4.850	5.180				



Part no.

**QKE13C**

**£1,685.00**

Additional final drive ratio

**QRE13C £625.00**

**Order now:**

Tel: +44 (0)1732 741144

Fax: +44 (0)1732 741555

Email: [info@quaife.co.uk](mailto:info@quaife.co.uk)

Web: [www.quaife.co.uk](http://www.quaife.co.uk)

Part no.

**QKE6C**

**£3,045.00**

2-speed Autograss gearkit

**QKE6C £1,380.00**

Additional final drive ratio

**QRE6C £625.00**

Open face dog design

update kit

**QKE6CU £990.00**



# Vauxhall / Opel F16/F18/F20 Gearkit & GM F35 Synchro Gearkit



## Astra / Kadett F16/F18/F20 6-Speed Dog Engagement

- 6-speed dog engagement gearkit
- Converts standard box to 6-speed
- Straight cut, close ratio
- Includes crownwheel & pinion and heavy duty end cover
- Choice of final drive and 5th, 6th gear ratios
- Comprehensive kit – includes selectors
- Input shaft – 7/8" 20T spline
- Optional Quaife ATB & Tran-X LSD differential
- Optional gearlever and turret available – see page 86

### Gear Ratios

1st	2nd	3rd	4th	5th	6th
2.308	1.867	1.555	1.350	1.174	1.045
				1.130	0.960
					0.916

### Final Drive Ratios

4.200	4.500	4.846	5.180
-------	-------	-------	-------

## Chevrolet/Opel/Saab/Vauxhall F35 6-Speed synchro gearkit

- Suitable for vehicles using the (GM) F35 gearbox
- Converts standard box to 6-speed
- 6-speed synchromesh gearkit
- Helical, close ratio gears
- Includes crownwheel & pinion
- Quaife ATB differential

### Gear Ratios

1st	2nd	3rd	4th	5th	6th
3.000	1.933	1.368	1.045	0.833	0.704

### Final Drive Ratios

4.071



Vauxhall / Opel

Part no.

**QKE11C**

**£3,935.00**

Additional final drive ratio

**QRE11C      £655.00**

Open face dog  
design update kit

**QKE11CU      £1265.00**

Part no.

**QKE20C**

**£POA**

**Order now:**

Tel: +44 (0)1732 741144

Fax: +44 (0)1732 741555

Email: [info@quaife.co.uk](mailto:info@quaife.co.uk)

Web: [www.quaife.co.uk](http://www.quaife.co.uk)

## Opel Manta / Ascona 4-Speed Synchro

- 4-speed synchromesh gearkit
- Straight cut, close ratio
- Retains original mainshaft
- Optional steel baulk rings
- Includes spigot bearing

### Gear Ratios

1st	2nd	3rd	4th
2.250	1.578	1.224	1.000

## Volvo 240 4-Speed Synchro (M45)

- 4-speed synchromesh gearkit
- Straight cut, close ratio
- Needle roller bearings support mainshaft gears
- Retains standard mainshaft

### Gear Ratios

1st	2nd	3rd	4th
2.432	1.658	1.222	1.000



Part no.

**QKE2C**

**£755.00**

Open Manta steel baulk rings 3rd-4th

**D1A1-232      £122.00**

### Order now:

Tel: +44 (0)1732 741144

Fax: +44 (0)1732 741555

Email: [info@quaife.co.uk](mailto:info@quaife.co.uk)

Web: [www.quaife.co.uk](http://www.quaife.co.uk)

Part no.

**QKE5S**

**£915.00**

### English / Atlas Axle Kit

The Quaife English / Atlas axle kit dramatically improves the strength and longevity of an axle by removing the weight of the vehicle from the halfshafts themselves and putting it onto the axle tube.

- Axle kit contains complete car set – 2 hubs & 2 shafts
- Bearing size increased utilising double row ball bearing
- Semi floating halfshaft design, with separate flange
- Easy shaft removal – retained by two screws only
- Suitable for drum or disc brake axles
- 3 lengths of 12mm or classic 7/16 studs available
- Large choice of halfshafts – others available to order
- Available with Gp1 or Gp4 wheel studs

Item no.	Part no.	Description	Qty.
1	See below	Halfshaft	2
2	F3Z1-03	Halfshaft flange	2
3	F3Z1-04	Rear stub axle	2
4	F3Z1-06	Rear wheel stud – M12 x 1.5	8
5	F3Z1-08	Rear wheel hub disc	2
6	F3Z1-09	Rear wheel stud – long M12 x 1.5	8
7	F3Z1-10	Rear wheel stud $\frac{7}{16}$ " UNF	8
8	F3Z1-18	Rear wheel stud, Gp4 spec	8
9	F4Z1-05	Atlas Conversion sleeve (not shown)	2

10	F4Z1-06	Rear stub axle – weld-on type	2
11	F1A1-56	Locknut	2
12	F1A2-62	M24x2.0 All steel locking nut	2
13	0193	Lockwasher	2
14	0195	Bearing	2
15	0196	Oil seal – 64 x 80 x 8	2
16	0198	O ring – $1\frac{3}{16}$ "id x $1\frac{5}{16}$ "od x $\frac{3}{32}$ " sect	2
17	0221	Socket head capscrew $\frac{5}{16}$ " UNF x $\frac{7}{8}$ " lg	8
18	2235	O ring – $3\frac{1}{4}$ "id x $3\frac{3}{8}$ " od x $\frac{1}{16}$ " sect	2
19	0458	Socket head CSK screw M6 x 1.0 x 20 lg	4

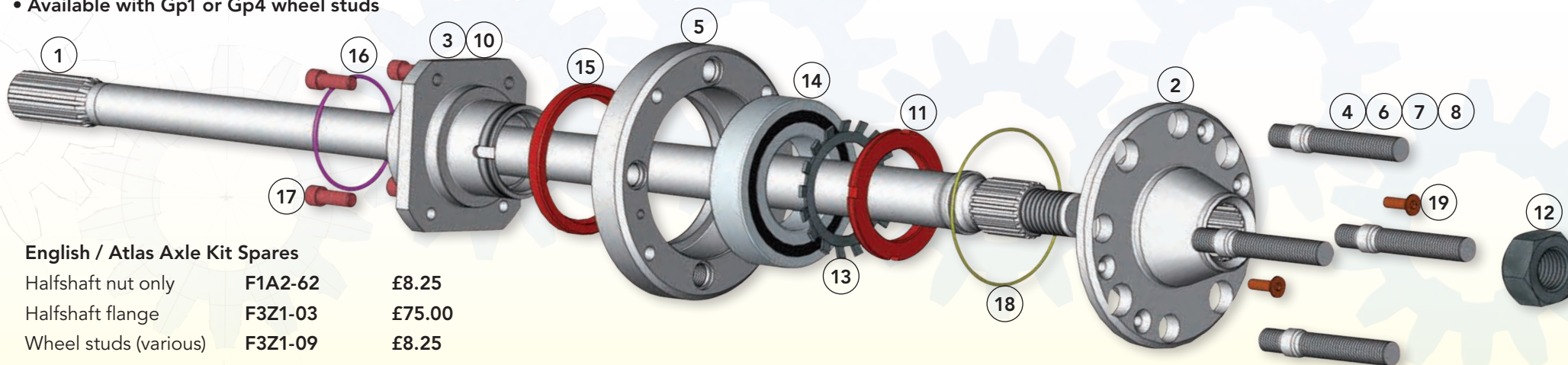

### English / Atlas Axle Kit Spares

Halfshaft nut only	F1A2-62	£8.25
Halfshaft flange	F3Z1-03	£75.00
Wheel studs (various)	F3Z1-09	£8.25
Wheel studs (Gp4)	F3Z1-18	£10.50

### Halfshafts Available For Axle Kits

Anglia 22T	660mm	F4Z2-08	£112.00
Anglia 16T	660mm	F3Z2-16	£112.00
Lotus Cortina 22T	708mm	F4Z2-02S	£112.00
Lotus Cortina 16T	708mm	F3Z2-07S	£112.00
Escort Gp5 18T HD	715mm	F1A2-69	£146.00
Escort 22T	730mm	F4Z2-02	£112.00
Escort 16T	730mm	F3Z2-07	£112.00

English = 22T    Capri = 16T    Gp4 ZF = 18T

Escort 18T	730mm	F1A2-67	£112.00
Escort 22T	770mm	F4Z2-07	£112.00
Capri 18T	770mm	F1A2-39	£112.00
Capri 18T HD	770mm	F1A2-66	£146.00
Capri 16T	770mm	F3Z2-02	£112.00
Capri 16T	790mm	F24Z2-05	£112.00
Capri 18T	820mm	F1A2-61	£117.00

Part no.

QAF4Z (std shafts)  
£740.00

QAF4Z (HD shafts)  
£810.00

### Order now:

Tel: +44 (0)1732 741144

Fax: +44 (0)1732 741555

Email: info@quaife.co.uk

Web: www.quaife.co.uk



## Atlas Gp4 Halfshafts

- 2-piece separate shaft and flange
- Large diameter shafts for strength and durability
- 770mm long with Gp4 ZF spline (18T)
- Optional Gp4 spline side gears to fit ZF LSD and Quaife ATB differential
- Heavy duty version available

Atlas Gp4 halfshaft	<b>F1A2-39</b>	<b>£112.00</b>
Atlas Gp4 halfshaft (HD)	<b>F1A2-66</b>	<b>£146.00</b>
Atlas Gp4 halfshaft (HD Gun drilled)	<b>F1A2-70</b>	<b>£225.00</b>
Atlas Gp4 halfshaft (HD 300M/ V132)	<b>F1A2-71</b>	<b>£225.00</b>
Atlas Gp4 flange	<b>D1A1-126</b>	<b>£76.50</b>

## Atlas Gp1 Halfshafts

- 2-piece separate shaft and flange
- Larger diameter shafts for strength and durability
- Flange is used to retain original bearing – when fitting latest Gp1 flange bearing retaining plate bore requires machining
- Gp4 ZF spline (18T) available
- Can be cut down to English Axle length – 95mm long spline
- Optional Gp4 spline side gears fit Quaife ATB differential
- Heavy duty version available

Atlas Gp1 halfshaft 18T	<b>D1T2-14</b>	<b>£128.50</b>
Atlas Gp1 halfshaft 18T (HD)	<b>D1T2-29</b>	<b>£161.00</b>
Atlas Gp1 halfshaft 16T	<b>D1T2-21</b>	<b>£128.50</b>
Atlas Gp1 halfshaft 16T (HD)	<b>D1T2-30</b>	<b>£161.00</b>
Atlas Gp1 flange	<b>D1T1-02</b>	<b>£84.75</b>
Atlas Gp1 flange (Un-drilled)	<b>D1T1-24</b>	<b>£84.75</b>

## English Gp1 Halfshafts

- 2-piece separate shaft and flange
- Standard English (22T) spline
- Flange is used to retain original bearing
- Shafts are standard English Axle length
- Can be cut down – 89mm long spline
- Uses later Mk2 bearing, does not fit Cortina Mk1 or any other axle using the early narrow bearing

English Gp1 halfshaft	<b>D1T2-18</b>	<b>£128.50</b>
English Gp1 flange	<b>D1T1-19</b>	<b>£84.75</b>

## English Plate Diff Side Gears

- Replace original Salisbury side gears
- Available with English or Capri spline

22 spline	<b>F4Z1-11</b>	<b>£90.00</b>
16 spline	<b>F4Z1-12</b>	<b>£90.00</b>

## Gp4 Spline Side Gears

- Used to convert a differential from standard Capri to Gp4 spline (18T)
- Enables use of larger diameter shafts

Gp4 spline side gears for ZF LSD	<b>F1A1-60</b>	<b>£87.50</b>
Gp4 spline side gears for Quaife ATB differential	<b>F6Z4-11/12</b>	<b>£90.00</b>

- High strength steel housing replicates original Ford part
- Uses Atlas crownwheel and pinion
- New crownwheel & pinion sets available – see page 97

Axle with plain cover

**QAF6ZP**

£POA

Axle with Watts linkage cover

**QAF6ZW**

£POA

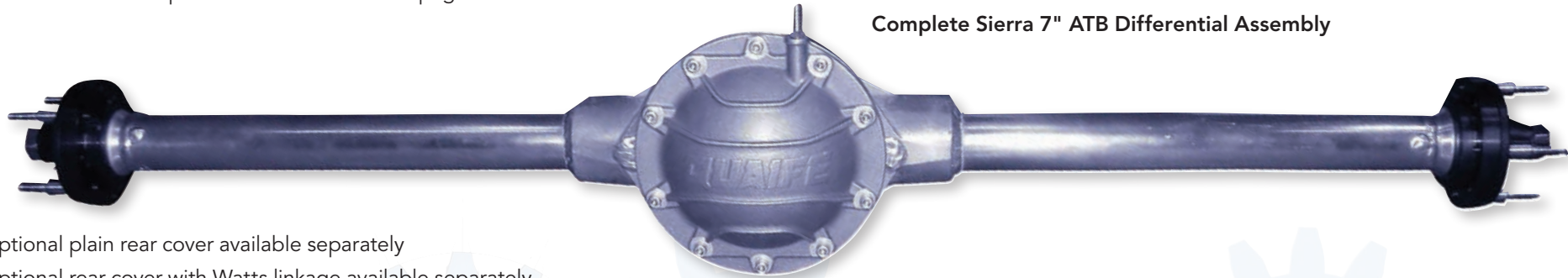

**Complete Sierra 7" ATB Differential Assembly**

- Optional plain rear cover available separately
- Optional rear cover with Watts linkage available separately
- Direct fit for Quaife ATB differential
- Uses Quaife axle kit – see page 90

Housing only

**QAF6Z**

£POA

#### Quaife Differential Assembly

- Complete diff units for independent suspension systems
- Designed for sub frame mounting
- Optional extension tubes, used if axle is offset from vehicle centreline to ensure even length shafts
- Choice of standard or pad type Quaife ATB differential
- Tran-X LSD available
- Uses Atlas crownwheel and pinion – see page 97

Complete Quaife differential with housing

**QDE5G**

**£2,575.00**

Drive shaft extension tube

£POA



Ford Sierra 7" Quaife ATB diff assembly  
(uses new cases & CWP)

**QAF15ZQ**     **£1,475.00**

Ford Sierra 7" Quaife ATB diff assembly  
with flanges (uses new cases & CWP)

**QAF15ZQFL**     **£1,675.00**

Ford Sierra 7" crownwheel & pinion set  
(see page 97)

**TRF56Z**     **from £270.00  
to £475.00**

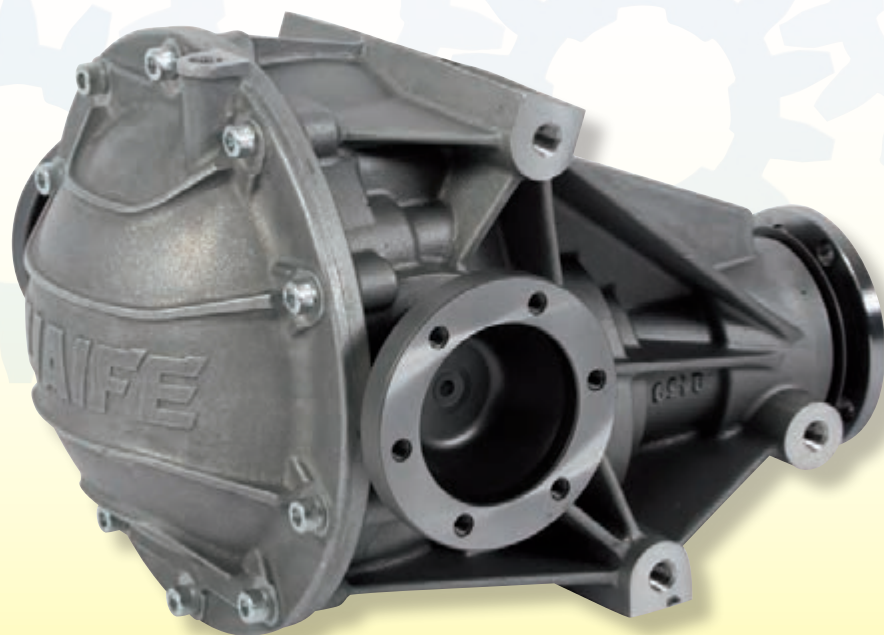
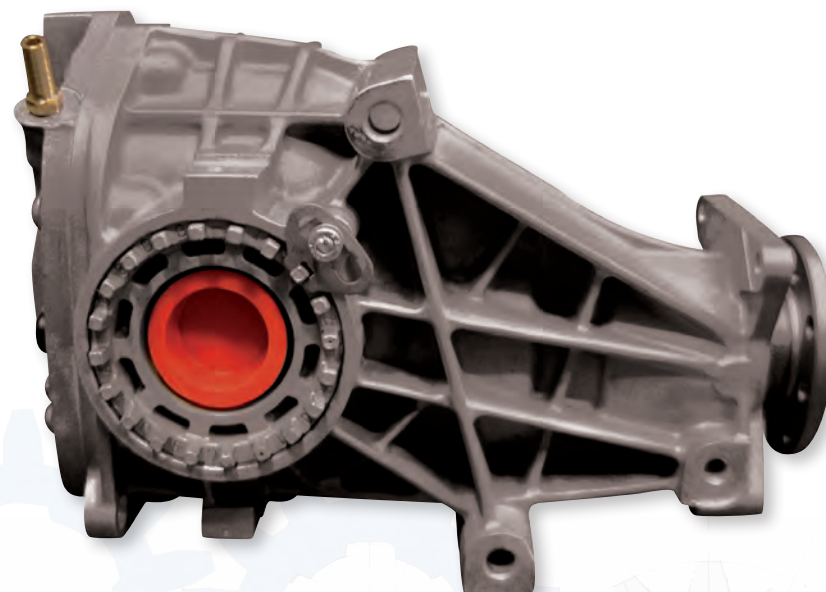

### Atlas Independent Differential Assembly

- Alloy case
- Uses Atlas crownwheel & pinion
- New crownwheel & pinion sets available – see page 97
- Bolt fixing same as Sierra 7"
- For high power applications where Sierra 7" is not strong enough
- Dimensions between input and output flanges differ from Sierra 7" mounting points

**QAF6ZFL**     **£1995.00**



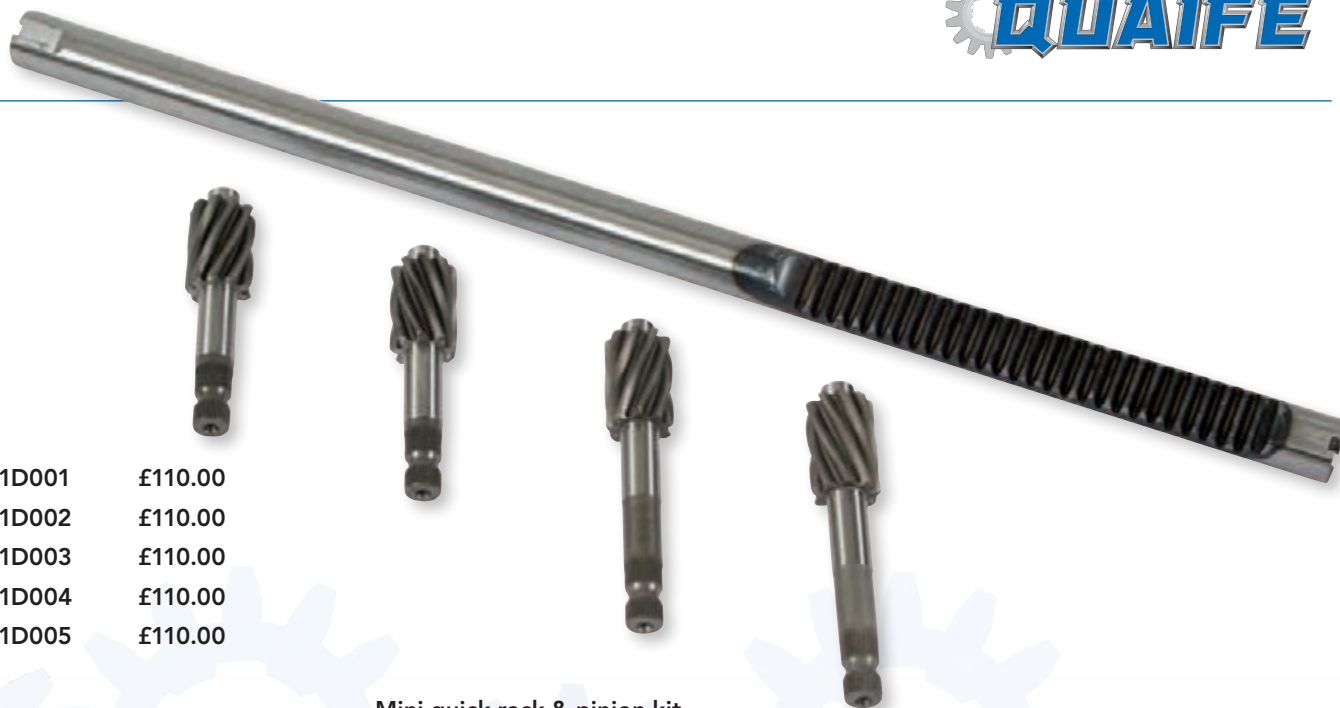

#### Ford Escort Mk1/Mk2 Quick Rack & Pinion Kit

- LHD 2.5 turns lock to lock
- RHD 2.2 or 2.5 turns lock to lock
- RHD 2.2 available with long or short pinion shaft
- Does not fit Quinton Hazell rack

LHD 2.5 (short)	QSD1D001	£110.00
RHD 2.2 (long)	QSD1D002	£110.00
RHD 2.2 (short)	QSD1D003	£110.00
RHD 2.5 (short)	QSD1D004	£110.00
LHD 2.5 (long)	QSD1D005	£110.00

#### Ford Escort Mk3/4 FWD Quick Rack & Pinion Kit

RHD 2.83 turns lock to lock	QSF10Z001	£125.00
-----------------------------	-----------	---------

#### Ford Sierra Quick Rack & Pinion Kit

LHD 2.8 turns lock to lock	QSF9Z001	£115.00
RHD 2.8 turns lock to lock	QSF9Z002	£115.00

#### Honda Civic Quick Rack & Pinion Kit

LHD 2.83 turns lock to lock (SH3L housing)	QSF10U001	£125.00
LHD 3.25 turns lock to lock (SR3L housing)	QSF11U001	£125.00

#### Honda CRX Quick Rack & Pinion Kit

RHD 2.75 lock to lock (VTI manual rack)	QSF19U001	£POA
RHD 2.75 lock to lock (1616 manual rack)	QSF19U002	£POA

#### MGC Quick Rack & Pinion Kit

RHD 2.9 turns lock to lock	QSF29K001	£POA
LHD 2.9 turns lock to lock	QSF29K002	£POA

#### Mini quick rack & pinion kit

RHD 2.23 turns lock to lock	QSF35K001	£POA
-----------------------------	-----------	------

#### Opel Kadett / Astra Quick Rack & Pinion Kit

Opel Kadett / Astra MK1 LHD 2.7 turns lock to lock	QSF6B001	£145.00
Opel Kadett C LHD 3.0 turns lock to lock	QSF20B001	£115.00

#### Opel Manta (A)\* / Ascona Quick Rack & Pinion Kit

*Will fit Manta (B) with mods		
LHD 2.5 turns lock to lock	QSF3B001	£115.00
RHD 2.5 turns lock to lock	QSF3B002	£115.00

#### Peugeot Quick Rack & Pinion Kit

Peugeot 205 RHD 2.78 turns lock to lock		
Flat drive pinion	QSF12H001	£135.00
Splined pinion	QSF12H002	£135.00
Peugeot 106 RHD 2.6 turns lock to lock	QSF16H001	£185.00
Citroën Saxo RHD 2.6 turns lock to lock	QSF16H 002	£185.00

### Porsche 911 Quick Rack & Pinion Kit

911/914 (1974-1989) LHD & RHD 2.5 turns lock to lock

**QSF3Q001 £155.00**

### Toyota Corolla AE86 Quick Rack & Pinion Kit

LHD 2.5 turns lock to lock

**QSF22E001 £145.00**

RHD 2.5 turns lock to lock

**QSF22E002 £145.00**

### Toyota MR2 Mk1 (AW11) Quick Rack & Pinion Kit

LHD 2.5 turns lock to lock

**QSF22E003 £145.00**

RHD 2.5 turns lock to lock

**QSF22E004 £145.00**

### Vauxhall Nova Quick Rack & Pinion Kit

LHD 2.5 turns lock to lock

**QSD1T001 £115.00**

RHD 2.5 turns lock to lock

**QSD1T002 £115.00**

### Volvo 240 Quick Rack & Pinion Kit

LHD 2.5 turns lock to lock

**QSF3J001 £145.00**

LHD 2.85 turns lock to lock

**QSF5J001 £POA**

### VW Quick Rack & Pinion Kit

Golf Mk1 LHD 3.1 turns lock to lock

**QSF7R001 £145.00**

Golf Mk2 LHD 2.9 turns lock to lock

**QSF6R001 £145.00**

Golf Mk1 RHD 2.9 turns lock to lock

**QSF18R001 £145.00**

Polo LHD 2.6 turns lock to lock

**QSF17R001 £145.00**

### Order now:

Tel: +44 (0)1732 741144

Fax: +44 (0)1732 741555

Email: [info@quaife.co.uk](mailto:info@quaife.co.uk)

Web: [www.quaife.co.uk](http://www.quaife.co.uk)

### Quaife Complete Central Quick Rack

- Made to customer requirements
- Complete central quick rack and pinion assembly
- Suitable for single seater applications
- 1.7 turns lock to lock
- Anodised aluminium clamps (available separately to customer specifications)

**QSH4Q £255.00**

**H4Q1-05 £35.00**

### Steering column pinion clamp



### Quaife complete LHD or RHD quick rack

**QSH5Q £POA**

### Ford Escort Mk1 & Mk2 Complete Heavy Duty Quick Rack

- RHD 2.2 or 2.5 turns lock to lock
- Anodised aluminium clamps
- Long and short pinions available

**QSF1Z £POA**

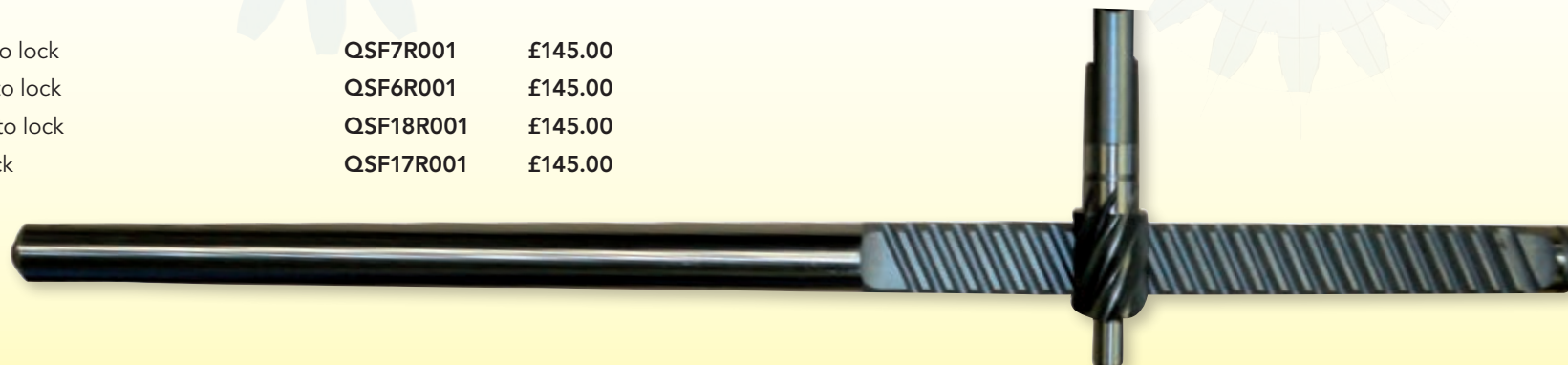



Powered by  **QUAIFE**

Tran-X is a long established brand known across the globe as a specialist in the entry level motorsport market. Concentrating heavily on the core motorsport transmission components, especially those used in Escorts and other Ford based vehicles, Tran-X has long been thought of as the 'go-to' supplier for many motorsport competitors.

Over the years Tran-X has expanded its range of plate type LSD units into a comprehensive list of great value motorsport differentials.

When the opportunity arose, Quaife Engineering jumped at the chance to acquire the strong Tran-X brand. The new 'Tran-X powered by Quaife' brand

now gives all involved with Clubman motorsport the confidence to continue competing with Tran-X drivetrain components with the knowledge that they are now supported by Quaife's 50 year heritage in all levels of motorsport design and manufacturing.

Together, Tran-X powered by Quaife will continue to expand the product range, introducing more great value for money components to the global Clubman market.



**All Tran-X powered by Quaife parts are ordered and invoiced through RT Quaife Engineering Ltd.**

All prices shown exclude VAT. | Freight can be arranged door-to-door – worldwide. | Telephone calls are recorded for training purposes.





## Performance Crownwheel & Pinion Kits

In a front-engined, rear wheel drive application, the crownwheel and pinion (CWP) transfers engine torque from the propshaft to the car's differential (LSD) and then to the road wheels via the drive (half) shafts. As a function of this process the crownwheel and pinion ratio is the principal variable controlling the overall gearing, which means that changing it has a significant effect on vehicle performance.

It is extremely important to tailor the CWP ratio to the engine characteristics and desired vehicle speed, whether it is for a road based trackday car or an outright competition vehicle that requires fine tuning from circuit to circuit. This is why Quaife Engineering has made a wide range of Tran-X CWP ratio sets available. The current range includes CWP sets for the Ford English, Atlas, Sierra 7" and Sierra 7½" axles, in ratios ranging from 3.14:1 to 5.86:1

The Tran-X CWP sets are precision engineered using superior high tensile steel billets on industry-leading Gleason gear cutting machines, Manganese Phosphate coated for added wear resistance and finally quality inspected to ISO9001-2008 standards.

Quaife can also provide lightweight aluminium alloy differential casings to complete an installation. These offer the twin advantages of making future CWP ratio changes considerably easier as well as reducing overall weight compared to the standard units. The Tran-X components can be supplied separately, or we can build complete differential assemblies incorporating the CWP set, new bearings, oil seals and gaskets. These complete units can be built with either the Quaife ATB or Tran-X LSD differential.

While Tran-X CWP ratios are available to suit a wide variety of performance requirements, we are keen to expand the range. Please contact Quaife's Technical Sales team for further enquiries.

## English Crownwheel & Pinion Kits

3.545:1	TRF54Z001	£265.00
3.777:1	TRF54Z002	£265.00
3.889:1	TRF54Z003	£265.00
4.111:1	TRF54Z004	£265.00
4.444:1	TRF54Z005	£265.00
4.714:1	TRF54Z006	£265.00
4.857:1	TRF54Z007	£265.00
5.143:1	TRF54Z008	£265.00
5.286:1	TRF54Z009	£265.00

## Atlas Crownwheel & Pinion Kits

3.111:1	TRF55Z009	£475.00
3.636:1	TRF55Z010	£475.00
4.111:1	TRF55Z001	£475.00
4.357:1	TRF55Z002	£475.00
4.625:1	TRF55Z003	£310.00
4.875:1	TRF55Z004	£475.00
5.143:1	TRF55Z005	£310.00
5.375:1	TRF55Z006	£475.00
5.857:1	TRF55Z007	£475.00

## Sierra 7½" Crownwheel & Pinion Kits

3.640:1 (Used Ford Original)	TRF58Z001	£300.00
3.920:1 (Used Ford Original)	TRF58Z002	£300.00
4.444:1	TRF58Z003	£POA
5.143:1	TRF58Z004	£POA

## Sierra 7" Crownwheel & Pinion Kits

3.140:1 (Used Ford Original)	TRF56Z001	£300.00
3.380:1 (Used Ford Original)	TRF56Z002	£300.00
3.620:1	TRF56Z003	£265.00
3.920:1	TRF56Z004	£265.00
4.111:1	TRF56Z005	£475.00
4.444:1	TRF56Z006	£475.00
4.714:1	TRF56Z007	£475.00



# Tran-X Powered by Plate-Type LSD



The Tran-X powered by Quaife LSD is a multiple plate limited slip differential. It features two ramp blocks sandwiching two planet carrier pins which sit in the radius between the leading and trailing ramp angle. As torque is applied to the differential's input, the pins ride up their respective leading ramps, pushing the blocks apart and increasing the transfer of torque across the axle.

The angle of this ramp determines how quickly this transfer occurs within the LSD. An angle of 35 degrees allows the blocks to be pushed apart more readily than a 55 degree setting, resulting in a more aggressive differential locking action. Plus, the preload setting dictates the contact friction between the plates themselves. The higher the preload, the more rapidly friction increases between the plates, creating a more aggressive locking action. Combined with the ramp angles, the preload allows subtle adjustments to the torque transfer characteristics allowing users to alter the dynamic balance of their car.

Typical settings for a lightweight track car would be 45/90, allowing progressive application of power for optimum acceleration. Some Tran-X powered by Quaife differentials feature dual ramp blocks, allowing ramp angles to be changed between two combinations, for example track and fast road settings (disassembly and reassembly of the LSD is required). We also offer a less aggressive 'super-lightweight' plate setting (preload 10-15 lbsft) for certain road and kit car applications to optimise performance and reduce operating noise.

We also now offer a 4-pin 'trials spec' (non LSD) differential for use where strength is vital, but all forms of LSD are banned by the rules of a particular discipline.



## NEW: LSD Tuning Kit

- 3 x dual ramp reaction blocks
- 1 x set of replacement plates
- 1 x storage case
- £195.00



<b>Part no.</b> TDX1E	Alfa 101 & 105
<b>Ramp Angles</b>	45/45 & 35/90 45/90 & 55/90 30/60 & 20/75 35/35 & 45/45 25/25 & 35/35
<b>Pre-Load (lbsft)</b>	10-15, 25-35 & 60-75
<b>Price</b>	LSD – £575.00 Trials – £555.00



<b>Part no.</b> TDX3K	Austin Healey 3000
<b>Ramp Angle</b>	45/45 30/60 35/90
<b>Pre-Load (lbsft)</b>	45-55 & 95-105
<b>Price</b>	LSD – £715.00



# Tran-X Plate-Type LSD

	<p><b>Part no. TDX9K</b>  <b>Ramp Angles</b>   <b>Pre-Load (lbsft)</b>  <b>Price</b></p>	<p>Mini Cooper S (Salisbury)            45/45 &amp; 35/90             10-15, 25-35 &amp; 60-75             LSD – £POA</p>
	<p><b>Part no. TDX6Z</b>  <b>Ramp Angle</b>   <b>Pre-Load (lbsft)</b>  <b>Price</b></p>	<p>Ford Atlas Axle            45/45            35/65            35/85             45-50 &amp; 85-95             16T LSD – £680.00            18T LSD – £680.00</p>
	<p><b>Part no. TDX1Z</b>  <b>Ramp Angle</b>   <b>Pre-Load (lbsft)</b>  <b>Price</b></p>	<p>Ford English Axle (Salisbury)            45/45            30/60            35/90             10-15, 30-40 &amp; 65-75             22T LSD – £475.00            16T LSD – £475.00</p>

	<p><b>Part no. TDX5Z</b>  <b>Ramp Angles</b>   <b>Pre-Load (lbsft)</b>  <b>Price</b></p>	<p>Ford English Axle (Tran-X)            45/45 &amp; 35/90            45/90 &amp; 55/90            30/60 &amp; 20/75            35/35 &amp; 45/45            25/25 &amp; 35/35             10-15, 25-35 &amp; 60-75             22T, 16T &amp; 18T LSD – £510.00*            Trials – £490.00*            *Includes side bearings</p>
	<p><b>Part no. TDX2Z</b>  <b>Part no. TDX3Z</b>  <b>Ramp Angles</b>   <b>Pre-Load (lbsft)</b>  <b>Price</b></p>	<p>Ford Fiesta BC/IB5            Ford BC/IB5 Sealed with flanges (£POA)             45/45 &amp; 35/90            45/90 &amp; 55/90            30/60 &amp; 20/75            35/35 &amp; 45/45            25/25 &amp; 35/35             10-15, 25-35 &amp; 60-75             LSD – £575.00            Trials – £555.00</p>
	<p><b>Part no. TDX2E</b>  <b>Ramp Angles</b>   <b>Pre-Load (lbsft)</b>  <b>Price</b></p>	<p>Toyota GT86 / Subaru BRZ            45/45 &amp; 35/90            45/90 &amp; 55/90            30/60 &amp; 20/75            35/35 &amp; 45/45            25/25 &amp; 35/35             10-15, 25-35 &amp; 60-75             LSD – £680.00</p>





<b>Part no. TDX4Z</b>	Ford Sierra 7"
<b>Ramp Angles</b>	45/45 & 35/90 45/90 & 55/90 30/60 & 20/75 35/35 & 45/45 25/25 & 35/35
<b>Pre-Load (lbsft)</b>	10-15, 25-35 & 60-75
<b>Price</b>	LSD – £575.00 Trials – £555.00



<b>Part no. TDX4K</b>	MGB Banjo Axle
<b>Ramp Angle</b>	45/45 30/60 35/90
<b>Pre-Load (lbsft)</b>	10-15, 30-40 & 65-75
<b>Price</b>	LSD – £680.00



<b>Part no. TDX1H</b>	Hillman Imp
<b>Ramp Angles</b>	45/45 & 35/90 45/90 & 55/90 30/60 & 20/75 35/35 & 45/45 25/25 & 35/35
<b>Pre-Load (lbsft)</b>	10-15, 25-35 & 60-75
<b>Price</b>	LSD – £715.00* Trials – £695.00* *Includes output shafts



<b>Part no. TDX5K</b>	MGB Salisbury Axle (3.9 & 3.7 CWP)
<b>Part no. TDX6K</b>	MGB V8 / MGC Salisbury Axle (3.3 & 3.07 CWP)
<b>Ramp Angle</b>	45/45 30/60 35/90
<b>Pre-Load (lbsft)</b>	45-55 & 95-105
<b>Price</b>	LSD – £680.00



<b>Part no. TDX2K</b>	MG Midget/AH Sprite
<b>Ramp Angles</b>	45/45 & 35/90 45/90 & 55/90 30/60 & 20/75 35/35 & 45/45 25/25 & 35/35
<b>Pre-Load (lbsft)</b>	10-15, 25-35 & 60-75
<b>Price</b>	LSD – £510.00* Trials – £490.00* *10T, 22T or 23T



<b>Part no. TDX1N</b>	BMW Mini (Getrag 285)
<b>Ramp Angles</b>	45/45 & 35/90 45/90 & 55/90 30/60 & 20/75 35/35 & 45/45 25/25 & 35/35
<b>Pre-Load (lbsft)</b>	10-15, 25-35 & 60-75
<b>Price</b>	LSD – £615.00 Trials – £595.00



# Tran-X Plate-Type LSD



**Part no. TDX2H**  
**Ramp Angles**

**Pre-Load (lbs/ft)**  
**Price**

Peugeot / Citroën MA  
45/45  
30/60  
25-35 & 65-75  
Customer Modified CW £615.00  
Tran-X modified customer  
supplied CW £715.00  
Supplied with Tran-X Straight Cut  
CWP £815.00\*  
\*CWP ratios – 4.92, 4.28, 3.9, 3.7



**Part no. TDX7K**  
**Ramp Angle**

**Pre-Load (lbsft)**  
**Price**

Triumph TR/Dolomite Sprint  
45/45  
30/60  
35/90  
10-15, 30-40 & 65-75  
LSD – £695.00



**Part no. TDX3H**  
**Ramp Angle**

**Pre-Load (lbsft)**  
**Price**

Peugeot / Citroën BE  
45/45  
30/60  
25-35 & 65-75  
LSD – £575.00  
Trials – £555.00



**Part no. TDX2B**  
**Ramp Angles**

**Pre-Load (lbsft)**  
**Price**

Vauxhall / Opel F16, F18, F20  
45/45 & 35/90  
45/90 & 55/90  
30/60 & 20/75  
35/35 & 45/45  
25/25 & 35/35  
10-15, 25-35 & 60-75  
LSD – £575.00  
Trials – £555.00



**Part no. TDX4H**  
**Ramp Angles**

**Pre-Load (lbsft)**  
**Price**

Talbot Sunbeam  
45/45 & 35/90  
45/90 & 55/90  
30/60 & 20/75  
35/35 & 45/45  
25/25 & 35/35  
10-15, 25-35 & 60-75  
LSD – £510.00  
Trials – £490.00



**Part no. TDX1B**  
**Ramp Angles**

**Pre-Load (lbsft)**  
**Price**

Vauxhall / Opel F10, F13, F15  
45/45 & 35/90  
45/90 & 55/90  
30/60 & 20/75  
35/35 & 45/45  
25/25 & 35/35  
10-15, 25-35 & 60-75  
22T or 34T LSD – £575.00  
Trials – £555.00



<b>Part no. TDX1R</b>	VAG 020 (109mm CW)
<b>Ramp Angles</b>	45/45 & 35/90 45/90 & 55/90 30/60 & 20/75 35/35 & 45/45 25/25 & 35/35
<b>Pre-Load (lbsft)</b>	10-15, 25-35 & 60-75
<b>Price</b>	LSD – £575.00 Trials – £555.00



<b>Part no. TDX2R</b>	VAG 02A (Push in)
<b>Ramp Angles</b>	45/45 & 35/90 45/90 & 55/90 30/60 & 20/75 35/35 & 45/45 25/25 & 35/35
<b>Pre-Load (lbsft)</b>	10-15, 25-35 & 60-75
<b>Price</b>	LSD – £575.00 Trials – £555.00



<b>Part no. TDX3R</b>	VAG 02J (Bolt in)
<b>Ramp Angles</b>	45/45 & 35/90 45/90 & 55/90 30/60 & 20/75 35/35 & 45/45 25/25 & 35/35
<b>Pre-Load (lbsft)</b>	10-15, 25-35 & 60-75
<b>Price</b>	LSD – £575.00 Trials – £555.00 *Requires standard retaining pads

### Ford English/Atlas Axle Gp1 Halfshafts and Flanges

Halfshafts are an often forgotten component (especially in an English or Atlas configuration) due to their enclosure within the axle casing. However, the upgrading of the engine, transmission and differential can render these shafts as the weakest link, particularly when you consider the majority of donor English or Atlas axles may have a considerable mileage prior to conversion for motorsport or fast road use.

Tran-X offer a range of larger diameter shafts fabricated from EN24T (high tensile alloy steel) which offers considerable sheer resistance compared to standard shaft. Machined from billet, there are three basic spline configurations: 22T English, 16T Atlas and, finally, 18T Atlas Gp4 and are available in varying lengths to accommodate specific axle widths.

If we do not stock the length of shaft you require or you have something that cannot be purchased off the shelf please contact us, as we can produce custom shafts to suit your needs, using a current sample or supplied drawings for manufacturing.

A half shaft upgrade reduces the risk of component sheer, but another failing of standard assemblies is the loosening of flange nuts, especially with intense motorsport use. Consequently, we have developed a flange design incorporating a coned washer and locking nut assembly which, during tightening, securely clamps the shaft's outer surface. We consider this an essential safety feature and, as such, any Tran-X half shaft upgrade requires the fitment of these new flanges which can be retro fitted with ease and with the minimum of fuss.

Gp1 Halfshaft sets include: halfshafts, flanges, coned washers and nuts **£405.00**

Gp1 'English' Halfshaft	22T	700-730mm	TX10607	<b>£135.00</b>
Gp1 'English' Halfshaft	22T	690mm	TX10608	<b>£135.00</b>
Gp1 'Atlas' Halfshaft	16T	700-730mm	TX10610	<b>£135.00</b>
Gp1 'Atlas' Halfshaft	16T	695mm	TX10860	<b>£135.00</b>
Gp1 ZF Halfshaft	18T	700-730mm	TX10901	<b>£135.00</b>
Gp1 ZF Halfshaft	18T	690mm	TX10900	<b>£135.00</b>
Gp1 Halfshaft Flange			TX10902	<b>£80.00</b>
Gp1 Coned Washer			TX10903	<b>£7.50</b>
Group Halfshaft Nut			TX10904	<b>£7.50</b>





# Ford Rocket Type E Synchromesh Gearkits

## Ford Rocket Synchro – Approx 230bhp

The ever-popular Rocket gearbox is well catered for with a range of ratios including our highly successful Hot Rod, F2 and Rally gearkits. Our straight cut Rocket gearkit comes with all gaskets, bearings and oil seals. All mainshaft gears utilise high performance coatings to reduce friction and aid oil absorption, resulting in a long-lasting driveline component.

**Tran-X Rocket Gearkit**                                 **TKX10Z**                 **£765.00**

Complete gearboxes can be assembled by our highly experienced technicians using a supplied donor unit. Complete boxes include our alloy top cover and breather system, as well as our one-piece, heavy duty operating block.

**Complete Ford Rocket Gearbox**                                 **TBX10Z**                 **£1,170.00\***

\*Donor unit must be supplied by customer



		1st GEAR				2nd GEAR				3rd GEAR	
M/S		27	26 <sup>†</sup>	26 <sup>†</sup>	25	23	22 <sup>†</sup>	22 <sup>†</sup>	20	22 <sup>†</sup>	22 <sup>†</sup>
		TX10093	TX10090	TX11726	TX10648	TX10092	TX10222	TX11727	TX10091	TX11728	TX10094
L/S		16	16	17	17	20	20	21	23	23	20 <sup>†</sup>
		TX10164	TX10164	TX10650	TX10650	TX10016	TX10017	TX11729	TX10018	TX10018	TX10037
INPUT	DROP										
17	25	2.482	2.390	2.249	2.163	1.691	1.618	1.541	1.279	1.407	1.618
TX10038	TX10019										
17	24	2.382	2.294	2.159	2.076	1.624	1.553	1.479	1.228	1.350	1.553
TX10038	TX10021										
15	27	3.038	2.925	2.753	2.647	2.070	1.980	1.886	1.565	1.722	1.980
TX10165	TX10029										
†Not the same gear		†Double gear for 2nd & 3rd – Replaces TX10016 in Hot Rod kits									



## Tran-X Sierra Type 9 Helical Gearkits

The first stage of any car modification should include optimising the ratios of the gearbox to suit the engine characteristics as well as the intended application. With this first stage in mind we have produced a range of helical upgrade kits for the standard Sierra T9 gearbox.

Whether you are restoring a car which utilises the Sierra T9 gearbox or building a new kit car based around the Sierra driveline, these close ratio helical kits provide the perfect solution for the road based, trackday car.

These are truly the first step onto the motorsport transmission ladder.



2.98 1st gear - Standard 4cyl layshaft bearing					Part No.	Price
2.98	1.97	1.37	1.00	0.82	TKX11Z	£270.00
2.98 1st gear - HD V6 layshaft conversion					Part No.	Price
2.98	1.97	1.37	1.00	0.82	TKX12Z	£350.00
2.83 HD helical complete gearkit					Part No.	Price
2.83	1.81	1.26	1.00	0.83	TKX13Z	£725.00
				0.85		
				0.87		
				0.89		
2.66 HD helical complete gearkit					Part No.	Price
2.66	1.75	1.26	1.00	0.82	TKX14Z	£900.00
				0.84		
				0.86		
				0.89		





# Ford Sierra Type 9 Gearkits

## Ford Sierra Type 9 Synchronesh – Approx 250bhp

The Tran-X straight cut Type 9 gearkit converts the standard mainshaft to use needle roller bearings under 1st and 2nd gears, eliminating problems from this highly stressed area of the gearbox.



### Tran-X Sierra Type 9 Gearkit

**TKX15Z £995.00**

Complete gearboxes can be supplied, including our alloy top cover and breather system along with our one-piece heavy duty operating block.

Available with long V6 input shaft at no extra cost (applicable to many kit cars).

**Complete Sierra Type 9 Gearbox (Iron Maincase) TBX15Z £1,745.00\***

**Complete Sierra Type 9 Gearbox (Alloy Maincase) TBX15Z £2,035.00\***

\*With exchange gearbox or £195.00 surcharge

		1st GEAR		2nd GEAR		3rd GEAR	5th GEAR				
	M/S	27	26	23	22	20	17	17	16	16	
		TX10001	TX10002	TX10039	TX10004	TX10005	TX10012	TX10012	TX10011	TX10011	
	L/S	16	16	20 <sup>†</sup>	20 <sup>†</sup>	23	26	27	26	27	
		TX10015	TX10015	TX10016	TX10017	TX10018	TX10014	TX10013	TX10014	TX10013	
	INPUT	DROP									
	17	25	2.482	2.390	1.691	1.618	1.279	0.962	0.926	0.905	0.871
4CYL	TX10007	TX10019									
V6	TX10009										
	17	24 <sup>†</sup>	2.382	2.294	1.624	1.553	1.228	0.923	0.889	0.869	0.837
4 CYL	TX10007	TX10021									
V6	TX10009										
	18	24 <sup>†</sup>	2.250	2.167	1.533	1.467	1.159	0.872	0.840	0.821	0.790
4CYL	TX10008	TX10020									
V6	TX10010										

<sup>†</sup>Not the same gear



## Quaife/Tran-X Products – Installation & Servicing

We offer a fitting service and aftersales support for all Quaife and Tran-X products, from a gear lever to a complete universal gearbox. Should the need arise when installing Quaife or Tran-X products, we can manufacture in-house components including bellhousings, driveline components, hubs and uprights, subframes and mountings.

Quaife offers servicing for the following products:

Transaxle gearbox	<b>£395.00</b>
4x4 gearbox	<b>£450.00</b>
Complete 5/6-speed 60G/69G gearbox	<b>£245.00</b>
Complete 5/6-speed 15G/27G gearbox	<b>£295.00</b>
Ford 4-speed gearbox	<b>£150.00</b>
Ford 5-speed gearbox / SL72	<b>£165.00</b>
Quaife FWD sequential gearbox	<b>£325.00</b>
FWD H-pattern gearbox	<b>£225.00</b>
Fitting ATB or LSD diff to FWD gearbox	<b>£210.00</b>
Fitting Quaife gearkit to FWD gearbox	<b>£325.00</b>
Fitting ATB or LSD diff to RWD unit	<b>£210.00</b>
Quaife reversing box	<b>£80.00</b>
All Quaife motorcycle gearboxes	<b>£150.00</b>
Quaife ATB differential	<b>£52.00</b>
Tran-X LSD differential	<b>£52.00</b>
Fitting/servicing all other products	<b>£POA</b>

**Maximise the life of your Quaife products: when installing – replace bearings, seals, gaskets etc. Unless experienced, use a professional service agent.**

## Transient Transmission testing dynamometer

Quaife has reinforced its ongoing commitment to constant improvement, quality and innovation by commissioning an advanced Axiline 97000EC transient transmission dynamometer to further expand the capabilities of its R&D department.

The Axiline dynamometer is a powerful, versatile machine, allowing all aspects of front and rear wheel drive transmissions to be validated in a strictly controlled in-house environment at Quaife's Sevenoaks headquarters.

Quaife's Axiline transmission testing dynamometer features extensive data acquisition and control, enabling technicians to accurately measure input and output torque. This bolsters the ability of Quaife's engineering team to optimise every component in a design by focusing on reducing internal power losses, as well as bearing performance, tooth form analysis and even gear casing function. In addition, gearshift quality and shift response time can be finely and repeatably analysed by Quaife's R&D team.

In projects ranging from high power motorsport applications to efficient electric vehicle and hybrid power transmission units, Quaife conducts extensive assessment of prototype designs, materials and techniques, to help improve durability, performance and weight.



**FUCHS-TITAN** has one of the world's largest ranges of specialist motorcycle and motorsport lubricants, developed on the race track to ensure ultimate performance and protection. Quaife Engineering Ltd recommends Titan Oils for its range of gearboxes, gear kits and differentials.

#### **TITAN RACE SYN 5**

**GL4 / GL5 SAE 75W / 90 Synthetic Gear and Transmission Oil £14.00**

RACE SYN 5 is a fully synthetic gear lubricant for manual transmissions and final drive units in high performance vehicles. Designed to meet or exceed the most stringent gear oil criteria, Race Syn 5 incorporates the very latest additive and synthetic lubrication technology and is recommended for use wherever a multigrade API GL5 lubricant is specified.

- Operates over a wide temperature range
- Gives true "stay in grade" performance
- Extends component life
- Enables optimum power release, even at low temperatures

#### **Recommended for:**

- Quaife dog engagement gearboxes
- Quaife Reversing Box and Quaife ATB differential and Reverse Box Unit
- Quaife gearbox internals and Quaife ATB differential
- Quaife ATB differential running in axle

#### **Others:**

- Gearboxes / gearkits running with 'plate-type' LSD units, refer to the LSD manufacturer for recommended lubricant.
- When running Quaife ATB differential with standard gearbox – as one unit – lubricate as per vehicle / gearbox manufacturers recommendation

#### **TITAN PRO SRG 75**

**GL 3 / GL4 100% ester synthetic racing gear oil £14.75**

Developed from aerospace technology for racing gear boxes where gear trains are subjected to very high power outputs and high shock loadings. Exceptional anti-seize and low friction properties extend component life and reduce power losses. Superior thermal stability maintains consistently high performance from start to chequered flag.

#### **Recommended for:**

- Synchromesh gearkits and gearboxes

Titan lubricants are available ex-stock through Quaife Engineering – please call for more details and we will be delighted to help you with your transmission oils requirements.

**Important: Quaife does not recommend the use of automatic transmission fluid**



#### **Order now:**

Tel: +44 (0)1732 741144

Fax: +44 (0)1732 741555

Email: [info@quaife.co.uk](mailto:info@quaife.co.uk)

Web: [www.quaife.co.uk](http://www.quaife.co.uk)

**Titan lubricants are available through Quaife Engineering – please call for more details.**

**Tel: +44 (0) 1732 741144 [info@quaife.co.uk](mailto:info@quaife.co.uk) | Fax: +44 (0) 1732 741555 [www.quaife.co.uk](http://www.quaife.co.uk)**





**QUAIFE®**

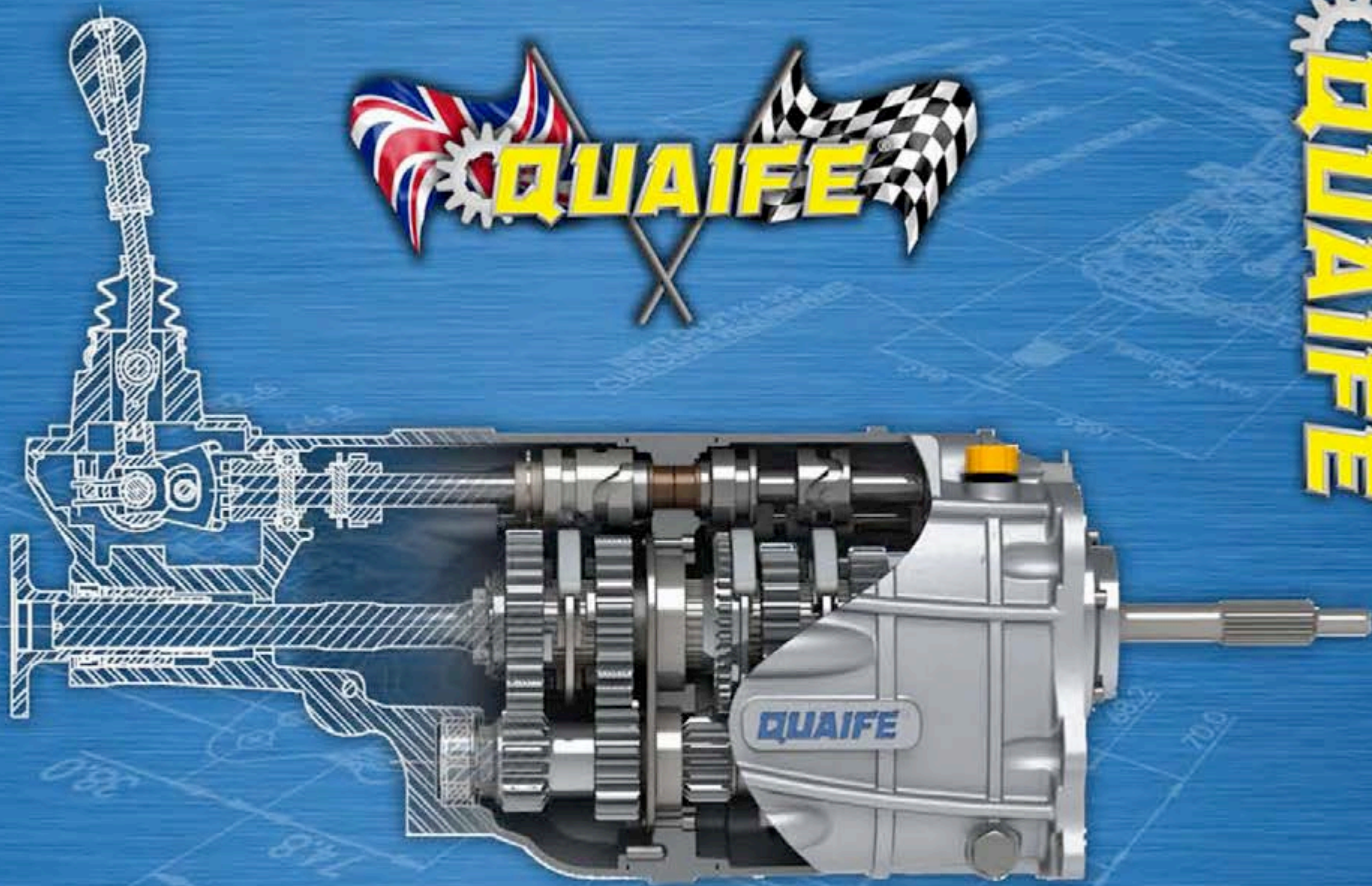

R.T. Quaife Engineering Ltd, Vestry Road, Sevenoaks, Kent TN14 5EL United Kingdom  
Tel: +44 (0) 1732 741144 / Fax +44 (0) 1732 741555/ info@quaife.co.uk/ www.quaife.co.uk